

JANUARY 1975

BME

BROADCAST MANAGEMENT/ENGINEERING



WJUU8669152-KW-753
 TN VA 24504-2404

13JRG

VA 24504

Focus on Electronic News Gathering

Also:

Great Idea Contest Finalists

Fact is, TRI has delivered more than 500 EA-5's since day one twenty-one months ago, which may be a record for stand alone editing systems.

Now for the good news.

TRI introduces the EA-4 End Insert Timer, an extremely useful plug-in module which enables editors to pre-program the length of their insert. A handy plus factor is that the EA-4 also operates as an electronic stop watch to time related segments.

So here's what you can do with a Sony 2850 plus the EA-5/EA-4 combination:

- Precisely end inserts
- Time related segments electronically
- Preview edits

- Edit accurately to video or audio cues
- Edit with frame accuracy
- Search at up to 5 times play speed in either direction
- Interface the 2850 with other makes or models
- Adjust the edit point after preview
- Make your edit decisions with true still-frame assistance
- Control end insert point from the console
- Monitor audio and video at the console

More good news for editors involves price. The cost? Less than \$6,000 plus \$1,250 for the insert timer. Installation time? An hour or so. Training period? Measured in minutes.

For a "hands-on" demo, or more information, contact us or the best video distributor in your area.

Chances are he's our distributor.

Television Research International, Inc.
1003 Elwell Court
Palo Alto, California 94303
415/961-7475

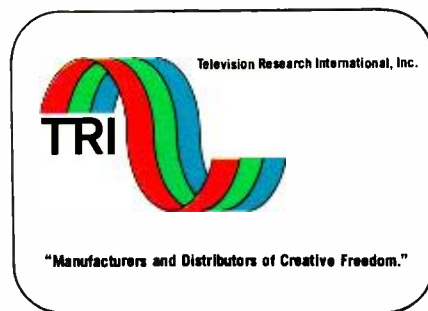

**53 broadcasters from New York to California,
from Louisiana to Minnesota are
editing with the
EA-5/Sony 2850 combination.**

Seeing is believing.



Circle 100 on Reader Service Card

THIS IS

NATIONAL BE KIND TO VIDEO TAPE TECHNICIANS WEEK

Indiana University

FEB 19 1976

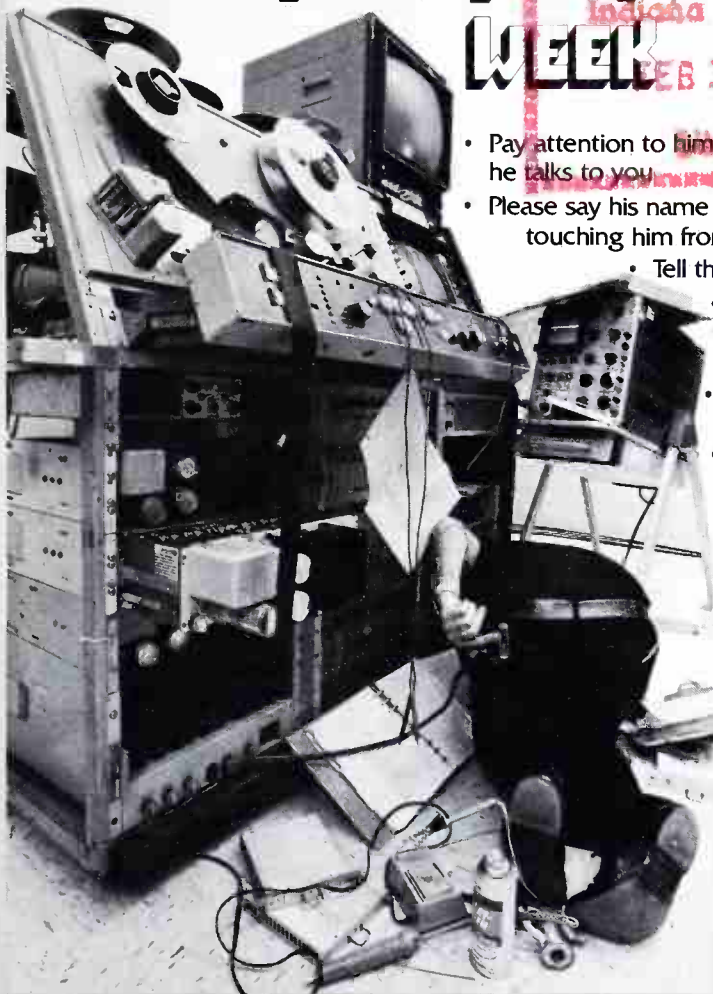

- Pay attention to him when he talks to you.
- Please say his name before touching him from behind.
- Tell the boss that he always works hard.
- Fetch him a cup of coffee at all times.
- Make an effort to remember his name.
- Agree that "the equipment did it to us again."
- Please do not steal his ashtray, coffee cup, or Playboy.
- Please don't hide his tweakers.

Brought to you as a public service by Videomax.

tax, it's a
giveaway
ster."

"Anyone can
call or write
for their copy."

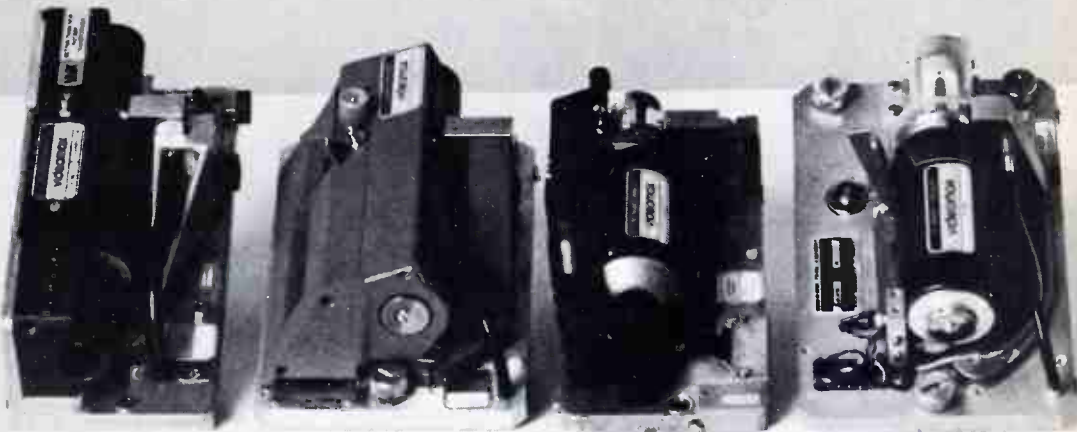

See Videomax for heads, "better than new," with the best price and performance advantages in the industry. And that's the truth.

VMXTM videomaxTM

Videomax Corporation, An Orrox Company
3303 Scott Boulevard, Santa Clara, CA 95050
Phone: (408) 988-2000 Telex: 910-338-0554

SALES & SERVICE - New York: (212)947-8031, Los Angeles: (213)980-7927, Washington: (301)384-4733

Circle 101 on Reader Service Card

BM/E

BROADCAST MANAGEMENT/ENGINEERING

TK
6630
-A1
B11
7.12

Dec

JANUARY 1976/VOLUME 12/NUMBER 1



This month's cover "focuses-in" on ENG cameras. The supply is ample and third generation models are appearing. For more details, turn to page 48.

BROADBAND INFORMATION SERVICES, INC.
295 Madison Ave.
New York, N.Y. 10017
212-685-5320

Editor
James A. Lippke

Associate Editor
Robin Lanier

Contributing Editor
Robert Wollins

Editorial Assistant
Karen Goudket

Art Director
Gus Sauter

Manager
Publication Services
Djuna Zellmer

Circulation Manager
Barbara B. Connolly

FCC Counsel
**Pittman Lovett Ford
and Hennessey**

Publisher
Charles C. Lenz Jr.

6 Broadcast Industry News

WRET-TV to send out satellite programming; BM/E's new address; ABC gets set for winter Olympics

24 Interpreting FCC Rules & Regulations

Music Format Contract Limitations

28 Great Idea Contest—Finalists

Pick three Panasonic color TV set and seven AM-FM clock radio winners by voting for the best Great Idea of 1975

42 Continuing—The EBS Story

Two-tone EBS systems: a good one should be easy to find

Special Emphasis On Electronic News Gathering

48 So Far It's All Go For Electronic News Gathering

ENG efforts to date are nothing but a succession of success stories. With less-than-ideal equipment, stations find they are doing a better job of news reporting than before and at less operating cost. New equipment to hit market in 1976 will make life even easier.

58 Total Changeover to ENG Improves "Product," Raises Efficiency, Saves Money At WOR-TV

The Minicam has allowed a return to the two-man news crew of the pre-film era.

62 At WGBH-TV, ENG Assures Realism, Keeps Newsmen Honest

Educational station uses the Shibaden SK-70 for back-of-the-news stories. Mini-equipment helps produce more mini-documentaries.

66 Two Remotes On Air Simultaneously With Frame Sync And Video Compressor At WTVJ, Miami

Station uses a CVS 600 in its ENG conversion to instantly lock an incoming video signal to station syn.

74 Broadcast Equipment

New and significant products

79 New Literature

Useful reading materials

INDIANA UNIVERSITY
LIBRARIES
BLOOMINGTON



BM/E, BROADCAST MANAGEMENT/ENGINEERING, is published monthly by Broadband Information Services, Inc. All notices pertaining to undeliverable mail or subscriptions should be addressed to 295 Madison Ave., New York, N.Y. 10017. BM/E is circulated without charge to those responsible for station operation and for specifying and authorizing the purchase of equipment used in broadcast facilities. These facilities include AM, FM, and TV broadcast stations; CATV systems; ETV stations; networks and studios; audio and video recording studios; consultants, etc. Subscription prices to others: \$15.00 one year, \$25.00 two years. Foreign: \$20.00 one year, \$35.00 two years. Foreign Air Mail: additional \$24.00. Copyright © 1976 by Broadband Information Services, Inc., New York City. Controlled circulation postage paid at East Stroudsburg, PA.

BROADCAST INDUSTRY NEWS

WRET-TV To Send Out Satellite Programming

Turner Communications Corp. has ordered an earth satellite send and receive station to relay the programs of WRET-TV Charlotte, N.C. to CATV systems in the U.S. The Scientific-Atlanta Video Earth Terminal and transmitter will be aimed at a satellite transponder over the equator and will beam back the station's programming to cable systems that have access to a reflector-receiver.

Although TV networks and some stations have used the orbiting satellites on occasion to bring programming across the country and over oceans, this is the first time that an individual station will put its full program schedule on satellite and make it available nationwide. WRET is an independent TV station operating on Channel 36 from Charlotte and carries extensive movie and

BM/E'S NEW ADDRESS

Please note that BM/E recently moved and we now have a new address to which all correspondence should be sent: 295 Madison Ave., N.Y., NY 10017. Our phone number, 212-685-5320, is unchanged.

sports programming.

Scientific-Atlanta will manufacture the Series 8000 Video Transmit/Receive Earth Station and associated equipment. A 10 meter/33' diameter dish-shaped reflector is the heart of the station which operates in the 5925-6424 MHz band for transmission and 3700-4200 MHz frequencies to receive.

No Increase In Predawn Power For Class II

The Commission recently reaffirmed the presunrise power restrictions im-

posed on a large number of Class I stations, to prevent interference with Class I co-channel stations.

In denying the request of KYMN Northfield, MN, for a rule-making providing an increase in presunrise power for many Class II stations, the FCC noted that a comprehensive study had established the limits set as necessary to prevent Class I interference in each case when Section 73.99 was adopted in 1967. KYMN, said the FCC, submitted no new information to support its request for an increase in presunrise power from 4.2 watts to 50 watts.

FCC Stands Firm On Sports Rules For Cable

Holding off broadcaster requests for a more restrictive ruling, and cable requests for elimination of all restrictions on sports importations, the FCC has said there will be no important changes in the sports blackout ruling for cable issued last July. The rule says that within a 35-mile protection zone, a local cable company, if requested not to, cannot import a telecast of a home game that is not being covered by local TV.

The commission did make a minor change: sports promoters or other owning the broadcast rights can notify the cable operator up to the Monday of the week preceding the wanted protection; under the original rule notification was due no later than six days before the calendar month of the broadcast.

In the same action, the FCC gave cable the right to substitute different programming from any other TV station for programs required to be deleted.

Teac Licenses dbx Noise Reduction

Teac tape recorders will offer dbx noise reduction under a license agreement just completed, dbx, Inc. recently announced. The license permits Teac to incorporate dbx noise reduction in machines in all three tape formats.

The system used will be the same 2:1 double ended compression/expansion system presently sold as an onboard accessory by dbx, and will be con-

continued on page



ABC Gets Set For Winter Olympics

Photograph above is a portion of ABC's Olympic's master control room being disassembled in New York before shipment to Innsbruck, Austria for the Winter Games, February 4-15. At Innsbruck, master control and studio go into a special TV center set up by the Austrian broadcasting agency, Oesterreichischer Rundfunk (ORF). Later, the same set-up will be shipped to Montreal for the Summer Games. ABC will do its own exclusive coverage of 90- and 70-meter ski jumps, hockey and figure skating. Holding blueprints of system is Joseph A. Maltz, senior A/V systems engineer.

MODEL 1600-2E SWITCHING SYSTEM

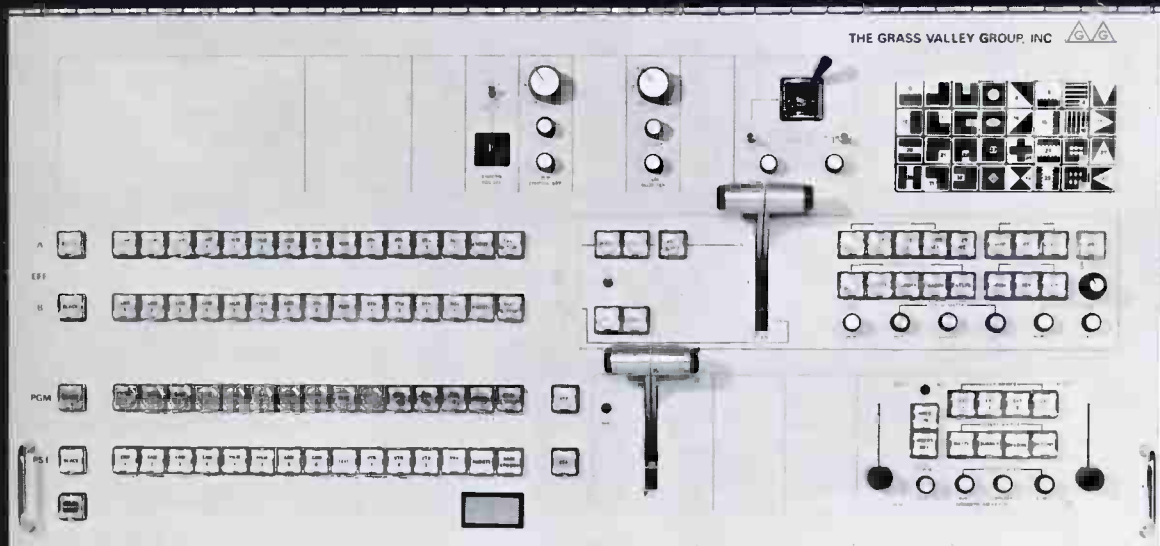

FEATURES

- 16 inputs (including color black and color background)
- 4 output buses: M/E-A, M/E-B, PGM, and PST
- Complete mix/effects system with modulated positioner, color matte generator, and pattern generator
- PGM/PST cut bar
- Color black generator
- Non-sync inhibit system
- Color background generator
- Camera tally system

OPTIONS

- RGB chroma keyer
- Shadow key system
- RGB switching matrix
- Borderline generators
- Video mixing amplifier to operate between PGM and PST buses
- Pre-roll system
- Downstream keyer with insert fade and fade-to-black controls
- Auxiliary switching bus with separate control panel

THE GRASS VALLEY GROUP, INC. 
A TEKTRONIX COMPANY

Station Plaza East
GREAT NECK, NY 11021
(516) 487-1311

4419 Van Nuys Blvd, Ste 307
SHERMAN OAKS, CA 91403
(213) 990-6172

1644 Tullie Cir, NE
ATLANTA, GA 30329
(404) 634-0521

P.O. Box 482
MABANK, TX 75147
(214) 887-1181

810 W Bristol Street
ELKHART, IN 46514
(219) 264-0931

WRET-TV To Send Out Satellite Programming

Turner Communications Corp. has ordered an earth satellite send and receive station to relay the programs of WRET-TV Charlotte, N.C. to CATV systems in the U.S. The Scientific-Atlanta Video Earth Terminal and transmitter will be aimed at a satellite transponder over the equator and will beam back the station's programming to cable systems that have access to a reflector-receiver.

Although TV networks and some stations have used the orbiting satellites on occasion to bring programming across the country and over oceans, this is the first time that an individual station will put its full program schedule on satellite and make it available nationwide. WRET is an independent TV station operating on Channel 36 from Charlotte and carries extensive movie and

BM/E'S NEW ADDRESS

Please note that BM/E recently moved and we now have a new address to which all correspondence should be sent: 295 Madison Ave., N.Y., NY 10017. Our phone number, 212-685-5320, is unchanged.

sports programming.

Scientific-Atlanta will manufacture the Series 8000 Video Transmit/Receive Earth Station and associated equipment. A 10 meter/33' diameter dish-shaped reflector is the heart of the station which operates in the 5925-6424 MHz band for transmission and 3700-4200 MHz frequencies to receive.

No Increase In Predawn Power For Class II

The Commission recently reaffirmed the presunrise power restrictions im-

posed on a large number of Class II stations, to prevent interference with Class I co-channel stations.

In denying the request of KYMN, Northfield, MN, for a rule-making providing an increase in presunrise power for many Class II stations, the FCC noted that a comprehensive study had established the limits set as necessary to prevent Class I interference in each case when Section 73.99 was adopted in 1967. KYMN, said the FCC, submitted no new information to support its request for an increase in presunrise power from 4.2 watts to 50 watts.

FCC Stands Firm On Sports Rules For Cable

Holding off broadcaster requests for a more restrictive ruling, and cable requests for elimination of all restriction on sports importations, the FCC has said there will be no important change in the sports blackout ruling for cable issued last July. The rule says that within a 35-mile protection zone, a local cable company, if requested not to, cannot import a telecast of a home game that is not being covered by local TV.

The commission did make a minor change: sports promoters or others owning the broadcast rights can notify the cable operator up to the Monday of the week preceding the wanted protection; under the original rule notification was due no later than six days before the calendar month of the broadcast.

In the same action, the FCC gave cable the right to substitute different programming from any other TV station for programs required to be deleted.

Teac Licenses dbx Noise Reduction

Teac tape recorders will offer dbx noise reduction under a license agreement just completed, dbx, Inc. recently announced. The license permits Teac to incorporate dbx noise reduction in its machines in all three tape formats.

The system used will be the same 2:1 double ended compression/expansion system presently sold as an onboard accessory by dbx, and will be com-

continued on page 8

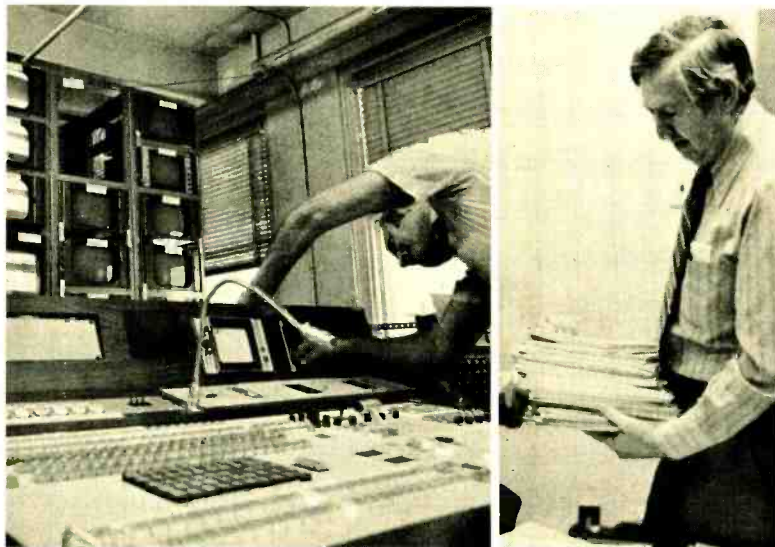

ABC Gets Set For Winter Olympics

Photograph above is a portion of ABC's Olympic's master control room being disassembled in New York before shipment to Innsbruck, Austria for the Winter Games, February 4-15. At Innsbruck, master control and studio go into a special TV center set up by the Austrian broadcasting agency, Oesterreichischer Rundfunk (ORF). Later, the same set-up will be shipped to Montreal for the Summer Games. ABC will do its own exclusive coverage of 90- and 70-meter ski jumps, hockey and figure skating. Holding blueprints of system is Joseph A. Maltz, senior A/V systems engineer.

Clean up your image with EEV camera tubes.



8872V 1 inch magnetic Vidicon
for use in color film
chain operation



P8130 to P8133 30mm Coaxial
Leddicon® series with internal
light blas. Replaces most integral
or separate mesh color camera
tubes. Available in standard layer
as well as extended red or green.



P888 4 1/2 inch Image Orthicon
for use as the luminance tube
in color cameras.



8134V1 1 inch electrostatic
focus Vidicon for color film
chain broadcast applications.
8480V1 1 1/2 inch tube for use
in luminance channel.

Clean, precise, consistent—EEV Leddicon® camera tubes are made to last. They can be used as replacements for Plumbicon® and Vistacon tubes.

Hundreds of stations in the USA and throughout the world use Leddicons to down costs and up quality.

From the same one-stop source you can also specify EEV Image Orthicons—we're the world's biggest makers—and Vidicons.

All EEV tubes are available for immediate delivery with fast service back-up. Contact us now for type lists and prices.



EEV NORTH AMERICA

ENGLISH ELECTRIC VALVE NORTH AMERICA LTD.

1 American Drive • Cheektowaga, NY 14225

(716) 632-5871 • TWX: (710) 523-1862

67 Westmore Drive • Rexdale, Ontario M9V 3Y6

(416) 745-9494 • Telex: 06 965864

A member of the GEC - English Electric Group of Companies

Leddicon is a registered trademark of English Electric Valve Company Limited

Plumbicon is a registered trademark of N.V. Philips' of Holland

www.americanradiohistory.com

Circle 102 on Reader Service Card

“For some straight talk about your underground construction needs...

call me and I'll arrange a Ditch Witch demonstration on your job site!”



“Ditch Witch performance, backed up with service and parts availability — that's what makes the difference! At Ditch Witch, we'll not only tell you — we'll *show* you how we can fulfill your job requirements with a full line of underground equipment — trenchers, vibratory plows and multi-purpose Modularmatics. We'll show you an independent professional dealer organization, too, with a complete parts inventory for faster service.

“Call us today and see what Ditch Witch can do for you. Compare us with the competition. Then decide which equipment and dealer provides you more for your invested dollar.

“At Ditch Witch, we tell it to you straight!”

Call (800) 654-6481 Toll Free for the name of the dealer nearest you.

Ditch Witch . . . equipment from 7 - to 195-HP.

CHARLES MACHINE WORKS, INC.

P.O. Box 66
Perry, Oklahoma 73077



Circle 103 on Reader Service Card

NEWS

patible with dbx noise reduction systems now in use.

Store Uses New Low-light Film For TV Commercials

Rich's Inc., a chain of 10 Atlanta area department stores, has begun utilizing the new 16mm Eastman color negative II film 7247 to film on-location commercials in low-light conditions.

The chain produces between 60 and 70 TV spots annually and the new Eastman film allows them to have the added realism of being produced on location—in stores, homes, apartments, etc.—where the audience can see Rich's products being worn or used by real people. The film now allows filming in these previously hard to light areas and has added to the impact of their ads.

Ampex Marketing New Portable Color Camera

Introduced as a prototype only six months ago at Montreux, Switzerland, Ampex Corp.'s new BCC-2 camera is now in standard production and on the market.

The new hand-held camera, which was demonstrated for the first time in the U.S. at the National Assoc. of Educational Broadcasters convention in Washington last Nov. 17-19, is designed for both studio use and on-location coverage of live news events and production video requirements.

Sonderling Installs Second “BAT” System

Sonderling Broadcasting Corp., operators of 10 radio stations and one TV station in seven major markets, have purchased a second “BAT” System from Paperwork Systems, Inc., creators of the BAT concept. The new order, for station WOPA/WBMX in Oak Park, Ill., follows a thorough test of the BAT system at Sonderling's WWRL in New York City, where their first system is installed.

The PSI BAT Systems are unique among computerized traffic, accounting, and billing systems because they utilize an in-house minicomputer, thus they are available at all times for station activities, and utilize no telephone lines for system operations.

FTC Chairman Wants Fairness Doctrine Lifted

Federal Trade Commission Chairman Lewis A. Engman has called upon Congress to abolish the “Fairness Doc-

continued on page 11

What is a company like us doing in a nice industry like this?



COMPACT BROADCAST CONSOLE
(Studio or Portable)

PLENTY!

Automated Processes' audio broadcasting equipment is now being used by ABC, CBS, NBC, PBS and NPR, among others, and our recording consoles by nearly every Major Record Label in the World.

We gained our reputation where audio is everything! Automated Processes is the leading U.S. manufacturer of audio consoles for recording studios worldwide.

Automated Processes applies its advanced design and production capabilities to broadcast consoles, putting at your fingertips the same on-air reliability, modular construction, flexibility of features and performance that have made us leaders.

Bring our superior technology into your control room. Call or write for details today, they are yours for the asking.

Here are some of our more than 100 audio products available:

- D.C. Control Consoles
- Conventional Consoles
- Audio Switching Systems
- Tape Synchronizers
- Microphone Preamps
- Line Amplifiers
- Audio Distribution Amplifiers
- Power Amplifiers
- Equalizers
- Compressor/Limiters
- Faders

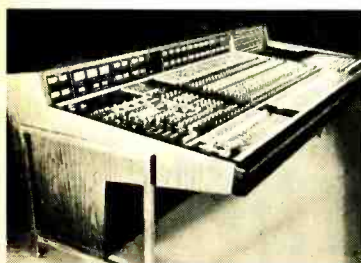

COMPLETE AUDIO PRODUCTION CONSOLE

Meet us at NAB, Booth No. 711.

INPUT CHANNEL
Mono-Stereo-Quad

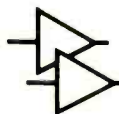

AUTOMATED PROCESSES, INC.
789 PARK AVENUE, HUNTINGTON, NEW YORK 11743 • 516-427-6024

Circle 104 on Reader Service Card

**THIS IS THE TUBE-
THE ORIGINAL 1¼ INCH PLUMBICON*
THAT WAS IN THE CAMERA
THAT REVOLUTIONIZED TV BROADCASTING
TEN YEARS AGO...**



**THIS IS THE 2/3 INCH VERSION
OF THAT PLUMBICON TUBE...
IT WILL CHANGE THE ENTIRE COURSE OF,
AND ADD IMPORTANT NEW DIMENSIONS
TO ELECTRONIC JOURNALISM.**



Amperex®

TOMORROW'S THINKING IN TODAY'S PRODUCTS

Sold through
North American Philips Electronic Component Corporation

*Trademark of N.V. Philips of The Netherlands



If broadcast journalism is distinguished primarily by its "immediacy," why should your viewers have to wait until color film is processed before they see your news telecasts?

Until now, they've had to wait because there was no TV camera tube made that was small enough for a really portable color camera capable of producing broadcast quality pictures in broadcast quality color.

The new 2/3-inch Plumbicon camera tube is now available for a new generation of portable, hand-held color cameras which will provide the same startlingly realistic color and dynamic resolution that revolutionized color telecasting ten years ago when its big brother was originally introduced.

With the 2/3-inch Plumbicon tube you'll get quality, and you'll get it without the delay and logistical complications of film.

The Amperex 2/3-inch Plumbicon TV camera tube offers:

- Better dynamic resolution than any other TV camera tube in the 2/3-inch category.
- Obviously superior color rendition.
- Excellent highlight-handling capability.
- Essentially zero lag over a wide range of lighting conditions.
- Low (and stable) dark current, combined with high signal-to-noise ratio for sharp, clean, noise-free images.
- Stable operation over a wide temperature range.

For additional information, contact Amperex Electronic Corporation, Electro-Optical Devices Division, Slatersville, Rhode Island 02876. Telephone: 401-762-3800

Amperex[®]

TOMORROW'S THINKING IN TODAY'S PRODUCTS

Sold through
South American Philips Electronic Component Corporation

NEWS

trine" as "an instance in which benevolent-sounding words have masked a miscarriage of our free market system." In an address to a meeting sponsored by the Communications Law Program of the University of California at Los Angeles' Law School last October, Engman said that there is a movement in Washington "to re-examine a great deal of what has long been presumed to be socially useful legislation." Engman feels that the Fairness Doctrine restricts a broadcaster because it forces him to weigh program material not only for its public interest value but also for its potential costs if reply time is required. In some instances, this has caused broadcasters to avoid presenting material on which contrasting views exist.

Radio Management Consultant Firm Formed

The establishment of "The Webster Group," a Radio Management Consultant organization, which will be the only New York-based activity of its type, specializing in station market, sales and profit improvement, has been announced.

Mr. Maurie Webster has assembled a group of specialists in various broadcast fields, which will permit him to offer complete professional services for station and group management, station investors, banks and brokers. The Webster Group will operate at 35 Sutton Place, N.Y., NY 10022; 212-371-4828.

Armstrong Awards Deadline Set

The Armstrong Memorial Research Foundation has set a February 23, 1976 deadline for entries from some 3,000 FM radio stations in the U.S. and Canada in the 12th Annual Armstrong Awards program for excellence and originality in FM broadcasting.

The Armstrong major awards for the best FM programs of 1975, consisting of plaques, are made in four categories: news, community service, music and educational/creative arts programming. Entry forms may be obtained by writing to Executive Director, Armstrong Awards, 510 Mudd Bldg., Columbia University, New York, NY 10027.

RCA Domsat Approved: To Be Separate From Globcom

In final action on an application filed in 1971, the FCC has approved a permanent RCA domestic satellite system, which will include RCA satellites to be

continued on page 12

New from Cooke

SMPTE

Video Taping/Editing Accessories

OUR NEW SMPTE TIME CODE SYSTEMS PROVIDE UNIQUE FEATURES AND THE LATEST STATE-OF-THE-ART DESIGNS.

SMPTE TIME CODE GENERATOR



Fully compatible with any SMPTE time code editing system, and meets or exceeds all SMPTE specs. Operates on sync or composite video input. Drop frame mode keeps generator on time when used with NTSC color video sources. Timing is unaffected by momentary power drop outs. Easy time set and large LED display readable at 30 feet. Two isolated outputs at +11 dBm into 600 ohms. Options include 10 outputs and 32 user bits per frame.

SMPTE TIME CODE READER/CHARACTER GENERATOR

Reads SMPTE code, generates 36 line high resolution digital characters, and adds time code characters to video. Valuable quad recorder time can be reduced by making editing decisions off-line on inexpensive helical or cassette machines. Allows time code display on studio or mobile unit monitors during production or VTR playback.



TAPE TIMER



Replaces mechanical counter and motion sensor on RCA and Ampex VTR's. Optical system provides greater accuracy than mechanical counter with the added feature of large easy to read LED digital display. Optional remote readouts and thumbwheel time set switches.

BE SURE WITH COOKE BROADCAST PRODUCTS

MASTER CLOCK SYSTEMS • VIDEO/AUDIO PATCHING EQUIPMENT • VIDEO/AUDIO/PULSE DISTRIBUTION MODULES • VIDEO TAPING/EDITING ACCESSORIES

COOKE ENGINEERING COMPANY

DIVISION OF DYNATECH LABORATORIES, INC.
900 SLATERS LANE, ALEXANDRIA, VA. 22314
TEL: 703-548-3889 TELEX: 89-9454

AVAILABLE IN CANADA FROM:

TELCOM RESEARCH

P. O. Box 271 STONEY CREEK, ONTARIO TEL: (416) 622-1372

NEWS

launched early this year (1976). RCA has been offering temporary satellite service, with FCC authorization, first through the Canadian "Anik," and more recently through the Western Union "Westar II."

The FCC approval for the permanent system planned by RCA includes construction permits for a number of earth stations, the first to be near New York, Chicago and Houston. The RCA Domsat, said the FCC, must be separate from RCA's international Globcom system, to avoid cross-subsidization that might create unfair rates.

AT&T and NCTA Reach Agreement On Pole Rates

The National Cable Television Association and American Telephone & Telegraph Co., in connection with an FCC proceeding, have reached an understanding on the regulation of rates to be charged CATV for attachment space on telephone poles. The agreement provides for a commitment by AT&T to hold rates at their current levels through 1978. The only exception is that AT&T may increase rates in California and Pennsylvania to a maximum of \$3.25 per pole from the current \$2.50 level.

NCTA Survey Shows Local Origination Down, Ads Up

The 1975 Local Origination Survey, published by the National Cable Television Association, shows a decline from last year's survey, but advertising revenues from local origination programming is up.

The survey for the year 1974 shows a drop from 589 to 484 systems which engaged in some form of local programming, a 22% drop. According to Broadband Communications Report, one reason given was "the state of the economy . . . Local origination—never a money-maker—was the first to feel the effects of this retrenchment."

Advertising gross revenues for stations providing local programming nearly doubled last year to a total of \$3.5 million. Copies of the report are available at \$4 non-members, \$2 members from the NCTA, 918 16th St., N.W., Washington, D.C. 20006.

FCC Briefs

The date when detented UHF tuners must have ± 1 MHz accuracy was extended to July 1, 1977, when several manufacturers said they would not have equipment in time for the original July 1, 1976 deadline . . . Cable operators

continued on page 14

WE
WANT
TO
BUY
THE
BEST
CAMERA

AT LAST, A PORTABLE TV CAMERA WITH FILM CAMERA FREEDOM. RCA TK-76.

A way through the maze.

Today, portable TV cameras come in so many degrees of convenience, performance and price that a wise choice is hard to make.

A way through the maze is to ask these questions about any portable camera:

- 1—Can it be ready for instant use in fast-moving situations?
- 2—Does it handle like your film cameras?
- 3—Will it work with as few controls and with the same ease as a film camera?
- 4—Will its weight, size, automatic features and freedom allow your newscaster to concentrate

on getting the best news pictures?

- 5—Does it have the quality for sports, documentaries, and some local spot commercial production?

Only one camera lets you answer "yes" to all five questions. The new TK-76 from RCA.

Backpack out, quality in.

The TK-76 is a 19-pound, self-contained unit without a backpack or separate camera control. Its picture quality is equal to far more costly cameras. Built-in performance features help maintain a quality picture automatically.

By designing all camera electronics into the camera head, one camera-person becomes a TV crew. Journalism, sports, documentaries, even some local spot commercials, can be done with film camera freedom and on-air immediacy.

Camera freedom is assured, since power may be from 12v. DC batteries

or a comfortable, waist-worn 6-pound rechargeable battery belt.

Under \$35,000.

Cost is a feature that makes the TK-76 downright revolutionary.

If you are going for two high quality

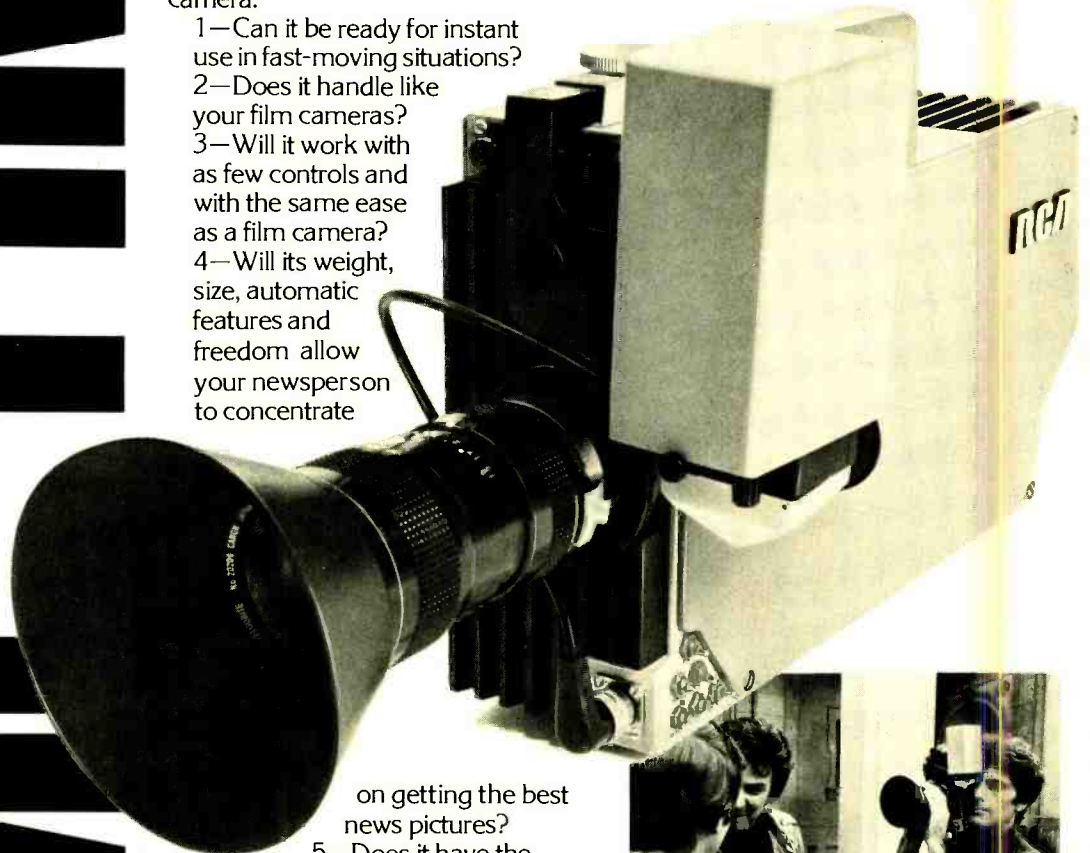

ENG cameras, you can afford three TK-76's. Moderate camera budget? You can now buy a lot more camera than you may have thought possible.

Available in 1976.

Networks, local broadcasters, tele-producers and corporate users have already ordered more than 100 TK-76 cameras for 1976 delivery. Contact your RCA Representative now about your TK-76.

RCA

NEWS

are no longer barred from offering **series type programs**, the FCC ruled, with an effective date of December 15, 1975 Readex Electronics has won a waiver of the rules to allow use in the Business Radio Service of developmental stations for **remote public utility meter reading** The **roughness corrections** for FM and TV signal contour predictions, set up by a new ruling effective August 1, 1975 have been postponed, pending amendments, until May 1, 1976, because they produced erroneous results in some terrains.

The celebrated case of **WJXT-TV, Jacksonville, FL**, owned by the Washington Post, apparently came to an end in November when the last competing applicant, St. John's TV, voluntarily resigned, and the FCC formally renewed the WJXT-TV license. There had been allegations in the press that contestants for the license were associated with former President Nixon, and were trying to "get" the Washington Post for its role in Watergate **New license renewal forms**, with additional questions about children's programming, will be sent to all stations whose licenses expire June 1, 1976 and thereafter, the FCC an-

nounced.

Detroit Will Host SMPTE's Winter TV Conference

Television Newsgathering and Digital Video are the subjects of SMPTE's 10th Annual Winter Television Conference, set for the Sheraton-Southfield hotel in Detroit, January 23-24, 1976, according to SMPTE vice-president for Television Affairs Joseph A. Flaherty, CBS Television Network.

Flaherty said that on this 10th anniversary of SMPTE's first Winter TV Conference, the SMPTE is returning to the inaugural city for a meeting on two of the industry's most pressing topics, which will have highly specialized sessions. In addition, there will be an exhibition, under one roof, of all significant ENG and digital equipment available today.

Among the highlights of the conference will be two major product unveilings, the Thomson-CSF Microcam Camera (smaller than a minicam) and the new CBS-Ampex Digital Still Storage Device.

The way the program is scheduled, Friday, Jan. 23, will be devoted to TV Newsgathering and Saturday, Jan. 24, will be devoted entirely to Digital Video. For more information contact the SMPTE at 862 Scarsdale Ave.,

Scarsdale, NY 10583; 914-472-6606.

More Meetings

Motion Picture Laboratories has scheduled a mini-seminar for Jan. 22, 1976, 7:30 p.m. at the Holiday Inn Central, Tampa, Fla. The program will be "The Film Laboratory," a 22-minute behind the door look at what happens to your film at the lab. Admission is free, but reservations are necessary. Contact MPL, Box 1758, Memphis, TN 38101; 901-774-4944 The School of Engineering and Applied Science, George Washington Univ., has scheduled a **Cable Television Techniques and Usage** course from Feb. 2-6, 1976 in Washington, D.C. For applications write Continuing Engineering Education Program, George Washington University, Washington, D.C. 20052; 202-676-6106.

The 16th International **Television Festival of Monte Carlo** will be held Feb. 12-22, 1976 **The Personal Communications 2-Way Radio Show** will be held March 30, 31, April 1, 1976 at the Las Vegas Hilton Hotel. For information contact Robert Black, President, The Show Company International, 1605 Cahuenga Blvd., Los Angeles, CA 90028.

continued on page 16

Lenco's 300 System is - - -



CHECK ONE

- A Digital Master Sync Generator with Change Over
(Can even use one External Generator)
- A Gen Loc Video Test Set (Your choice of Test Signals)
- A Gen Loc Digital Proc Amp (Helical or RS-170 Signals)
- A Unique Pulse Distribution System (Throw away your Pulse DA's & Delay Lines)
- A Remote Studio Pulse System (Use a jitter free Generator Substitute Unit)
- All of the Above! (And for Less Money!)

LENCO's 300 System's unique concept allows you to build any system to **your** requirements - - - Any way you want! Simply pick the units from the 29 available and plug them in. **No** modification or re-wiring of the shelf necessary!



"QUALITY WITH RELIABILITY AT A REASONABLE PRICE"

LENCO, INC., ELECTRONICS DIVISION

319 WEST MAIN ST., JACKSON, MO. 63755

314-243-3147

Circle 107 on Reader Service Card

The worst kept SECRET in tape editing systems



We tried to keep the lid on our brand new "buy what you need" System.

The word leaked out about System which is x-pandable full post production!



the 340X clear up to



The 340X can start where you are now and go on-line, or off-line, controlling quad VTR's, U-Matic or both!

The Fast, ac-less than you've got quad VTR editing.

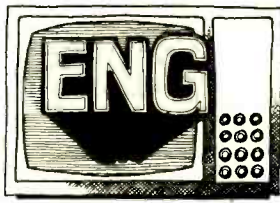

340X is your basic starter system. curate time code editing starting at \$30K. Add another \$10K and a neat ENG System in addition to

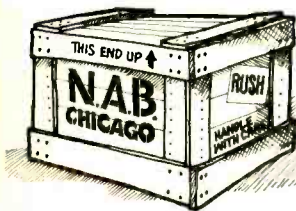

We were going to wait until March to intro the 340X. But you can book your order now for summer allocations.



Can't anybody keep a secret in this industry?

cmx systems

AN ORROX COMPANY
3303 Scott Boulevard, Santa Clara, CA 95050
Phone: (408)988-2000 Telex: 910-338-0554

Circle 108 on Reader Service Card

Business Briefs

Vari-L Co., Inc., Denver, Colo., producer of communications signal processing components, has been awarded a \$2.3 million contract from Sparton of Canada, Ltd., for the production of a set-top frequency translator to be used in CATV tuning systems A U.S. Navy contract for \$1.5 million to equip more than 22 ships with closed circuit

TV systems has been received by International Video Corp. The National Iranian Radio and TV network has ordered RCA TV studio and outside broadcast equipment valued at more than \$1 million The Broadcast Products Division of Harris Corp. has announced the receipt of a \$450,000 TV order from the Westinghouse Broadcasting Co. for a BTD-50L1, 50 kW dual IF modulated low band TV transmitter and a \$370,000 order from Harte-Hanks Television, Inc. for two BT-25L1 25 kW low band VHF TV transmitters.

Ultra Audio Products has made two major changes in its distribution program: the broadcast-grade array will be sold by reps directly to the user, while the industrial video products will now be sold through a limited number of systems-oriented video dealers Cox Data Systems has selected Ball Computer Products, Inc. as sole supplier of hardware for CDS' new in-house minicomputer system for TV stations Airpax Electronics, Florida-based manufacturer of electronics components, has announced the transfer of the exclusive distribution for Sanken Electronics products to American Data Corp., a subsidiary Lamb Laboratories, a division of Revox Corp., has announced their new exclusive representation arrangement with Rendar Instruments Fuji Photo Film U.S.A. Inc. has announced new reps for many areas of the U.S. For further information contact George T. Saddler, Marketing Manager, Audio Magnetic Tape Div., Fuji Photo Film U.S.A., Empire State Building, N.Y., NY 10001 Communication Planners, Inc., Philadelphia, Pa., has been selected by CCA Electronics Corp. to develop a Marketing Strategy Plan. JVC Electronics of Canada Ltd., located in Toronto, has been formed to handle sales and marketing in Canada of the Japan Victor Video lines The formation of a new operating unit of UMC Electronics has been formed to produce and market an exclusive line of broadcast cartridge tape record/playback machines A new firm, ADB, Inc., which will manufacture and market a complete line of Stage and TV Studio lighting and control systems has been announced as a joint venture of Connecticut International Corp., Windsor Locks, Cn. and ADB S.A. of Zaventem, Belgium GTE Sylvania Inc. and Motorola Inc. have announced an agreement in principle whereby GTE Sylvania will purchase certain assets of Motorola's Institutional Electronics Unit which leases and sells TV receivers and associated equipment to hotels and motels A new firm, Livingston Assocs., 800 Welch Road, #354, Palo Alto, CA 94304, has been formed to assist TV stations in CATV system relations Wometco Communications, Inc. has purchased the total outstanding stock of UltraCom of Wilson, Inc., which holds a franchise to operate a CATV system in Wilson, N.C. Cablewave Systems has opened an Eastern Regional office at P.O. Box 442, Somerville, NJ 08876, 201-526-5081 A new head office and laboratory will be opened by Dolby Laboratories, Inc. at 731 Sansome

continued on page 10

There are **2** great **CHYRON** systems

providing titling...graphics for television production

CHYRON II Electronic Graphics System,

unquestionably the most advanced and versatile system available today...the one system that offers the highest character resolution and do-it-yourself capability for unlimited type font and logo preparation, plus more features than any other TV graphics equipment.

CHYRON III Electronic Titling System,

At a moderate price CHYRON III provides more flexibility and quality than higher priced units, including unlimited font and logo interchangeability, large message storage capability, and character resolution exceeded only by CHYRON II.

For complete information write:

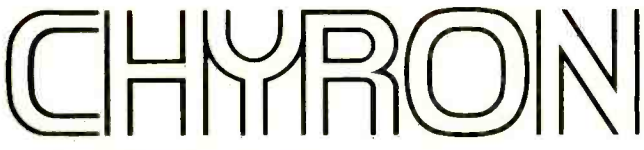

TELESYSTEMS DIVISION OF CHYRON CORPORATION

223 Newtown Road, Plainview, New York 11803 • 516 249-3296
851 Burlway Road, Burlingame, California 94010 • 415 348-1144

Circle 109 on Reader Service Card

a standard switcher from CDL?

only 90 day
delivery?

only \$34,000?*

that's right!



And in addition...
loaded with
"custom" features
and CDL Quality

it's the
VSP-1260S!

When you need a "Big" Video Production Switcher there are only a few manufacturers who make them. You've been accustomed to a "Big" delivery (6 months and longer), and at a "Big" price.

That's how it has been...

Here's how it is NOW!

- We've taken your most wanted "Custom" options and made them STANDARD.
- Standardizing features and production have reduced costs, and delivery schedules to less than 4 months.
- The VSP-1260S also has all the other original features of Central Dynamics' VSP-1200 Series Switchers.

You get these most wanted "Custom" features:

- 20 inputs
- 8 Busses including 2 Mix/Effects, Preview/Key, Program AND 2 prewired Utility busses for a variety of applications.
- VK-2140 Encoded Chroma Keyer integrated and timed into switcher and including 4x1 input selector.
- Dual 2x1 Chroma Key Switcher to delegate VK-2140 or RGB Chroma Keyer to either M/E amplifier.
- 1 Key Border Module: can be used with either Mix/Effects bus
- 32 Non-Repeating Effects Patterns
- Soft Edge Key
- Soft Edge Wipes and vignettes
- Spotlight & Mask Keys
- Non-Add Insert on each M/E
- Fade to Black from nonsynchronous sources
- Automatic Color Black system

Circle 110 on Reader Service Card

Following options can be added any time on a plug-in basis:

- RGB Chroma Keyer and input selector
- Utility Bus Control Panels
- Additional Key Border Module

To see the effects of VSP-1200 Series Switchers in color, request our "On-with-the-Show" Brochure.

You can also see the effects "Live". VSP-1200 Switchers are operating in most major cities across the country.



CENTRAL DYNAMICS LTD

Canada:
147 Hymus Blvd., Montreal, Que., H3P-1G1
514-697-0811

U.S.A.
230 Livingston Street, Northvale, N.J. 07647
201-767-1300

*U.S. Price

NOW 7GHz FOR **ENG**

The New Model 70 QP 1 is a Quad Polarized Receive Antenna System for Remote TV Broadcasting in the 7GHz Band.

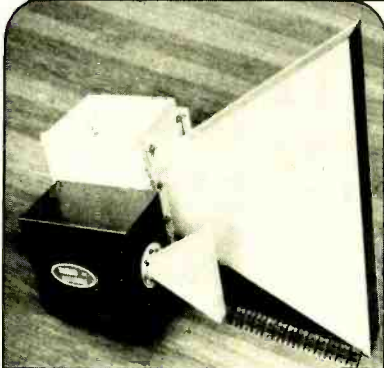

2 GHz & 7 GHz Antenna Elements side by side

FEATURES OF THE NEW MODEL 70 QP 1, 7GHz SYSTEM:

- 70% smaller than the NURAD 20 QP 1, 2 GHz equipment
- Provides identical electrical performance to the NURAD 20 QP 1, 4 element system

CONTACT NURAD FOR COMPLETE DETAILS

NURAD, Inc.

2165 Druid Park Drive
Baltimore, Md. 21211

PHONE:
301-462-1700

Circle 111 on Reader Service Card

THE NEW STANDARD COVERS AM BAND PLUS HARMONICS TO 5 MHz



The Model FIM-41 Field Strength Meter has many more features —

- Measures Harmonics to -80 dB
- High Adjacent Channel Rejection
- Ganged Oscillator/Receiver Tuning
- Stable Operation over wide Temperature Range
- Low Battery Drain Circuits
- Front Panel Speaker
- Large illuminated Meter and Tuning Dial
- Indicates field strength accurately down to 10 μ volts/M
- RF input jack for tuned voltmeter applications

CONTACT US NOW FOR COMPLETE DETAILS ON OUR LINE OF FIELD STRENGTH METERS

POTOMAC INSTRUMENTS

932 PHILADELPHIA AVE.
SILVER SPRING, MARYLAND 20910 (301) 589-3125

Circle 112 on Reader Service Card

NEWS

St., San Francisco, CA, 415-391-8892. The office will combine some of the activities now carried out in London with those of the present Dolby office in New York, which will close The Los Angeles offices of **Studio Film Exchange, Inc.** and its subsidiary Studio Tape Exchange have moved from Studio City to 6424 Santa Monica Blvd., Hollywood, CA **Audio Magnetics Canada, Ltd.**, the only major manufacturer producing a fully integrated line of tape and cassettes in Canada, has recently expanded to 26,000 sq. ft. its Toronto executive offices, manufacturing and shipping depot facilities.

MPCS Communications Industries, Inc. has changed its name to **MPCS Video Industries Inc.** The address, MPCS Video Center Building, 514 W. 57th St., N.Y., NY 10019, is unchanged **The Philadelphia office of the FCC** Field Operations Bureau, formerly located in the U.S. Customhouse, has been relocated to 11425 James A. Byrne Federal Courthouse, 601 Market St., Philadelphia, Pa. 19106; 215-597-4410.

The FCC has granted approval to **Teleprompter Corp.** to construct satellite earth receive stations in Eugene, Ore.; Mobile, Ala.; Tuscaloosa, Ala.; and Fairmont, W.V.

Goldmark Communications Corp. has been awarded a U.S. patent for a new electronic process that transfers motion picture films shot for wide screens in movie theaters directly to magnetic video tape for TV viewing without loss of essential picture information. The patent, No. 3,919,474, covers a process called "Transcan" which optically transforms picture images recorded on wide-screen motion picture film without distorting them to fit the much narrower viewing window of the home TV set

Skirpan Lighting Control Corp. has been issued a patent covering the AUTOCUE system, an electronic system which uses a computer and video display for stage lighting control in theatre and TV facilities, which they manufacture **Sarkes Tarzian, Inc.**, Broadcast Equipment Div. has sold all its patents for TV special effects and other products to **Vital Industries, Inc.** The patents cover digital and analog special effects and ancillary equipment **C-COR Electronics, Inc.** has announced a new Reliability Guarantee (fG Factor), which will be an additional, exclusive performance feature with the use of C-COR distribution equipment.

Cinema Products Corp. has an-

continued on page 20

If on-the-spot, Colour Video Coverage will improve your news gathering... Get together with Toshiba

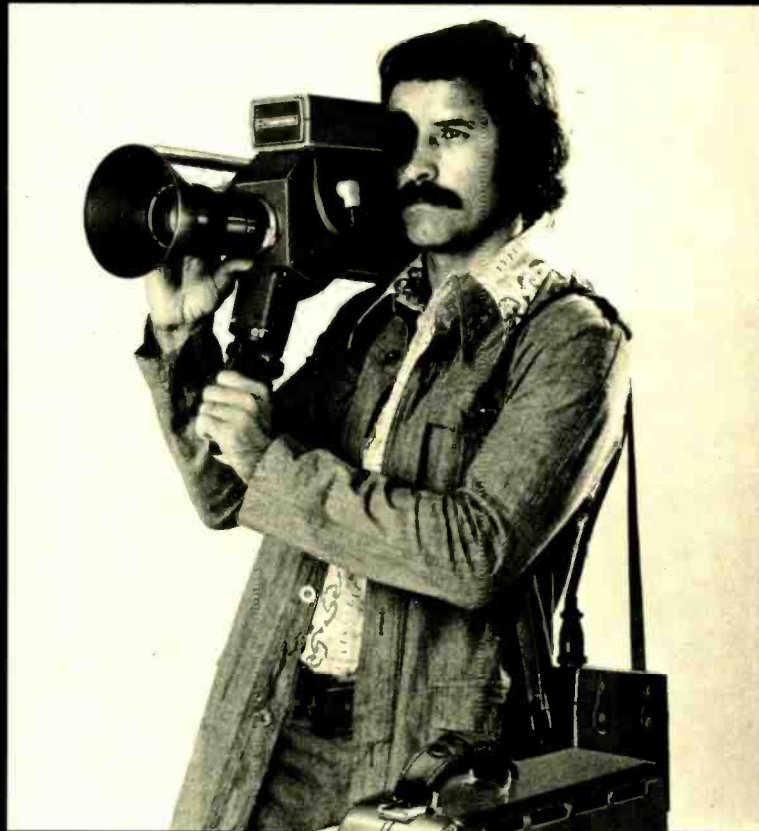

If you sat down with your news gathering team and listed the advantages of 16mm and video in getting good coverage, it's a pretty safe bet you'd use that information to design a camera like the CK-38. You'd develop a light-weight colour camera head, free of an encumbering backpack, with all the features of a studio camera. Including the capability for live, remote broadcasting and VTR recording. You'd make it easy to operate so any of your regular cine cameramen could use the new generation camera without special training. And that's just what Toshiba has done.



- Effective operating range as low as 20 foot candles
- Automatic colour balance adjustment
- Genlock input
- Built-in VTR control
- Standard lens f 2.0, 14mm-84mm zoom
- Three 2/3" CHALMICON pickup tubes
- High sensitivity, high SN ratio
- 1-1/2" adjustable BW electronic viewfinder
- Encoded video signal output (PAL, SECAM)
- 12V D.C. power supply
- Extensive use of IC's
- Total weight camera head, lens and viewer under 15 lbs.

For further information, please contact:



TOSHIBA
TOKYO SHIBAURA ELECTRIC CO., LTD.

Producer Goods Export Division: 1-6, Uchisaiwaicho, 1-chome, Chiyoda-ku, Tokyo, 100 Japan Cable: TOSHIBA TOKYO Telex: J22587 TOS-HIBA Phone: 501-5411

Circle 113 on Reader Service Card

A Two Faced Equalizer You Can Trust.

The Model 530 Dual Graphic Equalizer is two completely independent Graphic Equalizers with a common power supply. Each channel begins with a differential input stage, followed by nine variable equalizers centered at each octave from 50 Hz to 12.5 kHz. The transformer isolated outputs are capable of delivering +20 dBm into a 600 ohm load. The bridging inputs may be fed from balanced or unbalanced sources. Ideal for recording, sound reinforcement, radio and TV, commercial and home music systems. You'll like having two equalizers in one package . . . and at a two for one price, too. Get one from your UREI dealer.

UREI
QUALITY
OF COURSE

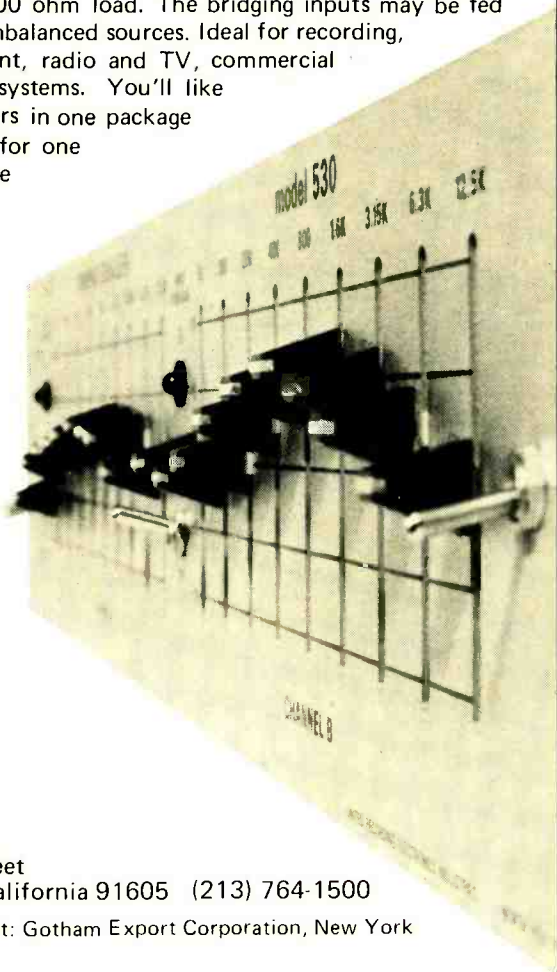

11922 Valerio Street
No. Hollywood, California 91605 (213) 764-1500
Exclusive export agent: Gotham Export Corporation, New York

Circle 114 on Reader Service Card

NEWS

nounced the availability of newly manufactured spare parts for the Worral head, the studio-type tripod gear head for heavy professional 35mm studio cameras **Varian** high-power transmitters are being used in five earth stations throughout Alaska as part of the satellite communications system being set up by RCA Alaska Communications, Inc. **Black Hawk Broadcasting Co.** will erect a 14,000 sq. ft. facility in Sioux City, Iowa to house TV station KTIV.

TeleVan Mobile Video Service Inc., the Northwest's newest remote broadcast facility, is ready for complete video tape production in the Portland, Ore. area. For information call 503-889-7731 **Eastman Kodak Co.** has announced the availability of Kodak Ektachrome EF film 7242 (tungsten) with a magnetic prestripe in a 200-ft. super 8 sound cartridge **Cinema Products'** second annual CP-16 Maintenance Training Seminar, held at the CP plant in Los Angeles, had a record attendance of over 150 professional cameramen and service technicians.

Two new membership categories have been established by the **NCTA**: Affiliate Membership and Individual Patron Membership, which will be included within the Associate Membership category. The basic "system membership" is available only to operating CATV systems and franchises Tougaloo College in Mississippi, a leading black institution of higher learning in the South, has received a grant of \$200,000 from the **CBS Foundation** for an endowed scholarship program.

Financial Briefs

Ampex Corp. has announced that net earnings for fiscal year 1975 were \$10.3 million, up \$4.9 million, or 89% over fiscal year 1974. Pre-tax earnings from continuing operations were \$6.0 million, up 35% over 1974. Total revenues were \$244.9 million, down 1% or \$3.4 million from 1974. Total earnings per share were \$0.95 compared to \$0.50 in 1974.

Cox Broadcasting Corp. has announced that their operating revenues for the nine months ending Sept. 30 were \$79,787 as compared to \$74,092 for the same period in 1974, an increase of 8%.

Gulf & Western Industries, Inc. and subsidiaries net sales and other operating revenues for the three months ended July 31, 1975 were \$677,519,000 as compared to

continued on page 22

now a color camera coupler... battery operated!

GK-2000U sync coupler weighs 26.4 lbs. with 2 CCU's. Approx. 19" wide, 14" deep, 6" high.

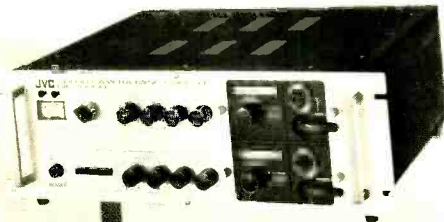

"Let's have a CU on camera 2... hold the LS on camera 1 and now a MCU on 2"... and so goes the direction.

A job for expensive broadcast equipment? Not if you have two JVC portable color cameras, a PV4800 tape deck, headphones, a hand mike and the all new GK-2000U which makes the two camera sync coupling possible.

Now you can get clean, noiseless, vertical interval color switching. Mix and match camera inputs when doing remotes... and all mind you... battery powered.

JVC has done it again. First in the field with a truly fine color portable and now the GK-2000U... the first battery or AC operated sync coupler.

Get a demonstration from your JVC video dealer and learn how you can dazzle the competition or your customers with this new found video capability.

JVC Industries, Inc., 58-75 Queens Midtown Expressway, Maspeth, N.Y. 11378, Tel.: (212) 476-8010. • In Chicago: 3012 Malmo Dr., Arlington Hgts., IL. 60005, Tel.: (312) 593-8997. • In Los Angeles: 1011 W. Artesia Blvd., Compton, CA. 90220, Tel.: (213) 537-8230.

JVC Best by Design

JVC

JVC INDUSTRIES, INC.

Circle 115 for literature
Circle 116 for a demonstration

JVC Industries, Inc.,
58-75 Queens Midtown Expwy.,
Maspeth, N.Y. 11378 • (212) 476-8010.
BM/E-176

Please send me information on

- 2 Camera synchronizer
- Camera
- VTR
- Complete system
- Please arrange a demonstration

Name _____

Title _____

Organization _____

Address _____

City _____

State _____ Zip _____

Telephone _____



ELIMINATE TAPE NOISE



WITH 30 DB NOISE REDUCTION AND 10 DB EXTRA HEADROOM

With dbx Model 142 noise reduction in the rack, you can:

- Nearly double the usable signal-to-noise ratio of your cartridge chain, studio master recorder, line and program amps, full-frequency land lines, and microwave links.
 - Make original tapes completely free of hiss or background noise on open reel, cartridge, or cassette format.
 - Duplicate tape through three or more generations without audible noise build-up.
- dbx noise reduction linearly compresses audio signals by a 2:1 ratio at the front end and produces an exact mirror image 1:2 expansion at the terminus of the audio chain.

True RMS level sensing circuitry insures perfect encode/decode tracking over a dynamic range well in excess of 100 dB irrespective of phase shifts in the transmission or storage medium. There is no breathing, pumping, or other coloration of the sound with dbx noise reduction, and there are no pilot tones or calibration levels to worry about.

dbx Model 142 provides two channels of broad-band audio noise reduction in excess of 30 dB coupled with an additional 10 dB increase in headroom for all components and lines included within the noise reduction loop.

For complete product information and list of demonstrating dbx dealers, circle reader service number or contact:

dbx *the new standard in noise reduction*
dbx, Incorporated
 296 Newton Street
 Waltham, Mass. 02154
 617/899-8090

Circle 117 on Reader Service Card

NEWS

\$639,173,000 in 1974. Net earnings after income taxes were \$38,552,000 as compared to \$27,196,000 in 1974, a rise of 42%. Net earnings for the nine months ending July 31 were \$140,055,000 as compared to \$100,646,000 in 1974, a rise of 39%.

In its annual report for the year ending June 30, 1975, **Harris Corp.** announced that net sales from continuing operations were \$479,058,000 as compared to \$436,657,000 in 1974, a rise of approximately 9%.

International Video Corp. has reported that first quarter sales for the period ending October 31, 1975 were \$6,819,000 and net income was \$114,000. This compares with sales of \$7,263,000 and net income of \$83,000 for the same period last year. The company had reported a loss of \$6,775,000 for the year ending July 31, 1975, on sales of \$24,833,000 and is extremely pleased on its return to profitability.

Jones Intercable Inc. announced revenues of \$517,126 during the company's past year of operation. The May 31, 1975 year-end results showed a loss of \$88,107 or \$0.04 per share for the company.

People

James E. Foss has been appointed Chief Engineer for the Buck Owens Stations Outlets in Bakersfield, CA, KUZZ AM & FM . . . **William B. Sanders** has been named Vice President and General Manager of the Mullins and Marion Broadcasting Co., licensee of radio stations WJAY-AM and WCIG-FM in Mullins, SC . . .

James C. Warner has been promoted to General Manager of WFLD-TV, Chicago, a Kaiser Broadcasting Co. station . . . **Jim Elrod** has been named Director of Operations for WMAZ-TV, Macon, GA . . .

L. William White has been named Vice President and General Manager of KBHK-TV, San Francisco, a Kaiser Broadcasting Co.

Allen Novick has been named National Sales Director of TEAC Corp. of America . . .

Fred J. Sawyer has been named General Sales Manager of the BIAS Div. of Data Communications Corp. . . .

Leslie K. Lear has joined Nurad, Inc. in the capacity of Director of Marketing . . .

H.F. Jones has joined Recortec, Inc. as National Sales Manager . . . **Richard C. Belmont** has been named Sales Manager at Modular Audio Products.

Samuel C. Jones has been promoted to the post of Sales Manager of the Robins-Fairchild Div. of Robins Industries Corp.

Fernseh means television.

NBC has the picture. They've fielded the Fernseh KCN into their O&O news operations.

Which gives NBC the flexibility and portability to get to where the news is.

And television means some good news, and some bad news. All of which means being there.

So you've got to be flexible. You've got to be portable. And you've got to be ready to go.

The battery operated KCN (shown with the cameraman) is completely self-contained and can be used in conjunction with a portable VTR.

Fernseh handheld camera systems are lightweight and offer the speed and portability you need for electronic journalism, plus the video quality required for television production excellence.

The KCR-40 (shown front and center) is

completely compatible with our standard KCU-40 and will operate from that system's electronics. You can roam 325 feet on a quarter-inch cable, 2600 on a half. With an additional 50 feet between the head and back pack.

Both KCR and KCN systems use the same camera head, which is the lightest in its class, weighing as little as a 16mm film camera.

Fernseh means television. Television good news.

We'd welcome the opportunity to demonstrate the superior capabilities of Fernseh television equipment. A call to your nearest office will bring any further information you require.

Saddle Brook, Headquarters (201) 797-7400
Chicago (312) 681-5000 Houston
(713) 688-9171 Los Angeles (213) 649-4330

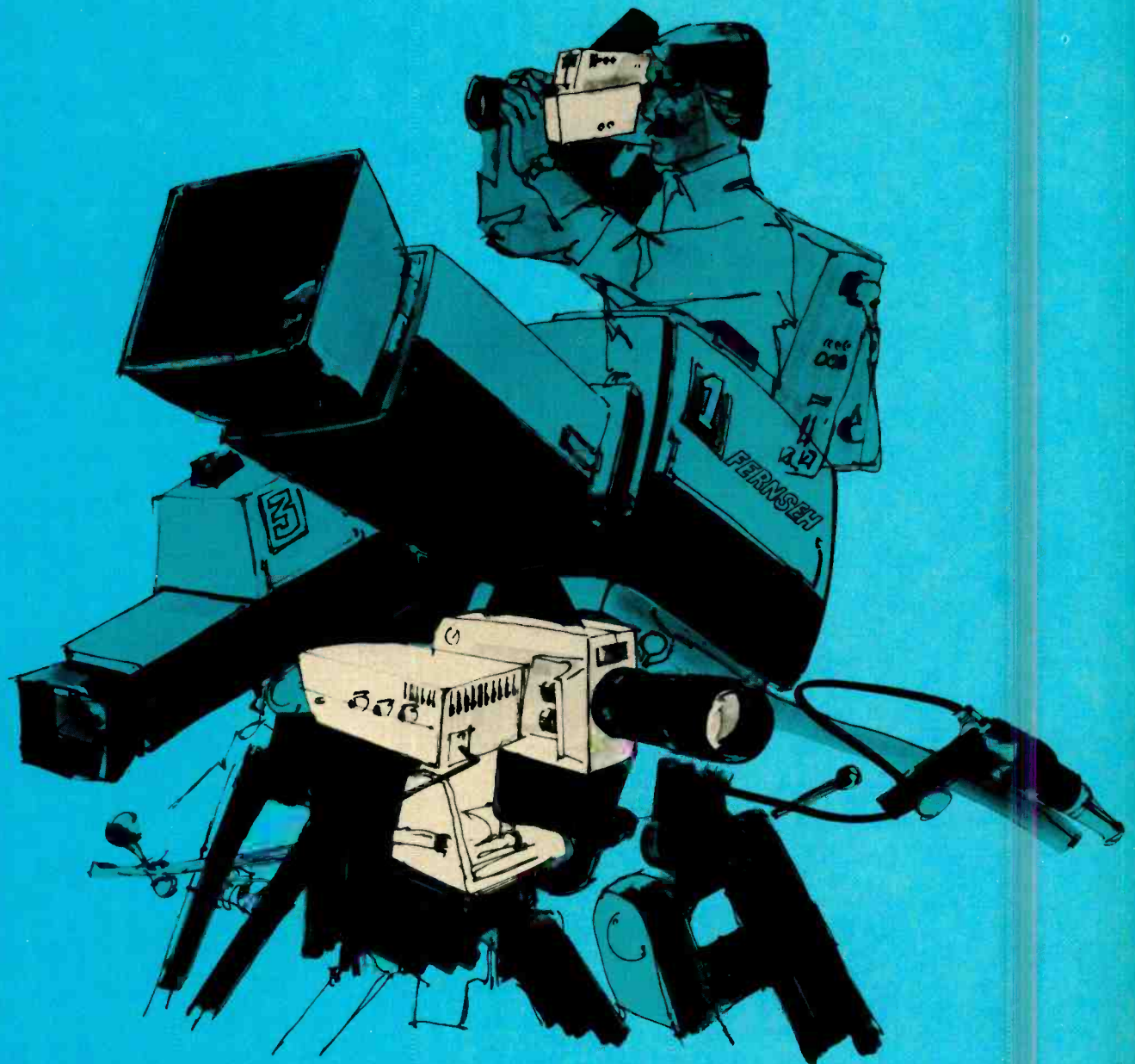

FERNSEH Robert Bosch Corporation

Circle 118 on Reader Service Card

INTERPRETING THE **FCC** RULES & REGULATIONS

Music Format Contract Limitations

By Frederick W. Ford and Lee G. Lovett Pittman. Lovett, Ford and Hennessey, Washington, D.C.

An objection by a Florida radio station in 1973 to the assignment of a nearby FM station's license¹ has led to a Commission *Report and Policy Statement*² on restrictive agreements in broadcaster-music format contracts.

The "Precipitating" Case

The licensee seeking to transfer the FM station had entered into a subscription agreement with a music format company to supply pre-taped music programming. The contract contained restrictions as to the amount of news and non-musical programming that the subscriber FM station could carry. The objecting station argued that these restrictions were contrary to the public interest because they limited the subscriber FM station's "discretion and flexibility" in programming and, hence, effectively usurped a primary right and responsibility of the broadcaster.

The Commission refused to address the objecting FM's programming restriction complaint on its face. Rather, said the Commission, the proper course of action would be to institute a rule-making proceeding on the subject. This it did in May 1973.

Proposed Rulemaking

The threshold question posed by the Commission's *Notice of Inquiry* was "whether music format service contracts have the potential to restrict programming flexibility and thereby amount to a contracted abdication by the licensee of its responsibility to the public and to the Commission."

Specifically, comments were requested concerning:

- (1) the extent to which program format subscription agreements contain restrictive provisions;
- (2) the degree to which the industry "enforces" these agreements by threatened or actual contract recession; and
- (3) the extent to which these restrictive provisions inhibit programming flexibility by licensees.

The Commission's Report

The Commission concluded that the issuance of a Policy Statement, rather than formulation of a rule, was appropriate. The policy statement accomplished two complementary functions. First, broadcasters were put on notice that certain "conduct" (in this case, abdication of programming discretion—a fundamental licensee responsibility) is deemed unsatisfactory and "not in the public interest." Second, regulatory flexibility was maintained to swiftly deal with new industry practices

that might ensue.

In contradistinction to the Policy Statement, a new rule prohibiting specific restrictive contract clauses infringes upon a broadcaster's freedom to contract as he chooses.

Further, adoption of a Policy Statement in no way diminished the Commission's enforcement powers. Instead of the threat of forfeiture imposition underlying violation of Commission Rules, the Commission

... already has adequate means of dealing with abdication of responsibility by licensees, and (the Commission) will scrutinize music format service contracts closely in this regard, when brought to (the Commission's) attention upon renewal, transfer assignment, or complaint. At that time (the Commission) will determine whether the contract or the licensee's operation under the contract amounts to an abdication of licensee responsibility in contravention of the public interest.

In addressing the substantive issues of restrictive provisions and cancellation clauses in music format contracts, the Commission found both to be contrary to the public interest if they "could potentially inhibit licensee responsibility." Thus, provisions specifically terminating music format contracts because of modification by the broadcaster are unacceptable. Further, even those provisions which give the music format company the optional legal right to terminate due to contract modification by the broadcaster are impermissible.

The Commission recognized that music format companies may wish to express their suggestions as to broadcast subscriber programming. Thus,

if provisions are mere representations, suggestions, or selection criteria, then the contract should so state. If they are modifiable without penalty or cancellation, then that should be expressed rather than the opposite.

Thus, contracts with language indicating that restrictive provisions and cancellation clauses are not legally binding, and are subordinated to Commission rules, regulations, policies and licensee responsibilities, do not impair the public interest.

The Policy Statement

The Commission cited 12 specific instances of contract provisions that it considers an abdication of the broadcast licensee's responsibility to exercise independent judgment in programming. This list is not exhaustive; rather, it is meant to (1) enumerate commonplace violative provisions, and (2) provide a basis by which to judge (by "extrapolation") which additional provisions would unduly fetter the licensee's programming discretion.

¹*Technico Leasing Inc.*, 27 RR 2d 880 (1973).

²*Report and Policy Statement in Docket No. 19743*, 35 RR 2d 819 (1975).

FCC RULES & REGS

The list includes those music format contract provisions which:

- (a) fix the number of broadcast hours;
- (b) prohibit AM/FM program duplication;
- (c) prohibit sub-carrier authorization;
- (d) require the exclusive use of a music format service;
- (e) prohibit the use of any other program sources;
- (f) prohibit an announcement of any kind by the broadcast station;
- (g) fix the number of commercials broadcast;
- (h) limit the content or source of any non-musical programming;
- (i) fix the amount of airtime for news, music or other programming;
- (j) prohibit automatic gain control of music format company supplied material;
- (k) fix the amount of format service company music broadcast; or
- (l) allow contract termination in the event of program changes made by the licensee in the exercise of his public interest programming responsibility.

Procedures

Broadcast licensees are not required (at least for the present) to file copies of their music format contracts with the Commission. Nor is there a specific requirement that such contracts be maintained in the station's public inspection file.

Further, the Commission expects that music format contracts already in force will be reformed to conform to the Policy Statement.

Conclusion

The practice of contracting with non-broadcasters to supply program tapes and formats on a subscription basis has proven quite successful, and has spread rapidly in the broadcast industry. The Commission's concern over certain restrictive programming provisions and termination clauses in music format contracts gave rise to a Policy Statement declaring these to be unacceptable when they limit the licensee's programming discretion.

The Commission's 1960 *Report and Policy Statement on Programming*³ succinctly sums up this most important licensee responsibility:

Broadcasting licensees must assume responsibility for all material which is broadcast through their facilities. This includes all programs and advertising material which they present to the public . . . This duty is personal to the licensee and may not be delegated. He is obligated to bring his positive responsibility affirmatively to bear upon all who have a hand in providing broadcast matter for transmission through his facilities so as to assure the discharge of his duty to provide acceptable program schedule consonant with operating in the public interest in his community. The broadcaster is obligated to make a positive, diligent and continuing effort, in good faith, to determine the tastes, needs and desires of the public in his community and to provide programming to meet those needs and interests. This gain is a duty personal to the licensee and may not be avoided by delegation of the responsibility to others.

³20 RR 1901.

BM/E

Profitable programming begins with Automated Systems from SMC

Make the most profit possible. Automate with a complete system from SMC—world's largest maker of broadcast automation equipment.

Choose from digital or sequential systems, or a customized system built and designed to meet your specific needs to help you realize more profit plus greater format control.

SMC can help you plan *and finance* an automated system that fits your budget and operation. SMC also has information on every major music format. Phone us today—or return the coupon below.

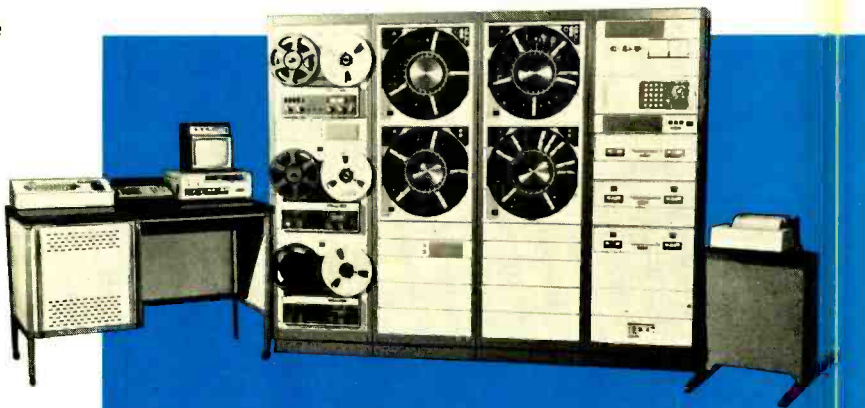

Systems Marketing Corporation

1019 West Washington Street
Bloomington, Illinois 61701
(309) 829-6373

Broadcast Automation—our only business

YES! I want to profit through automation.

Send complete information
and have your Representative call me.

Name _____

Station _____

Address _____

_____ Zip _____

Phone (area code) _____

75-102

Circle 119 on Reader Service Card

Ampex, the first announces the last wor

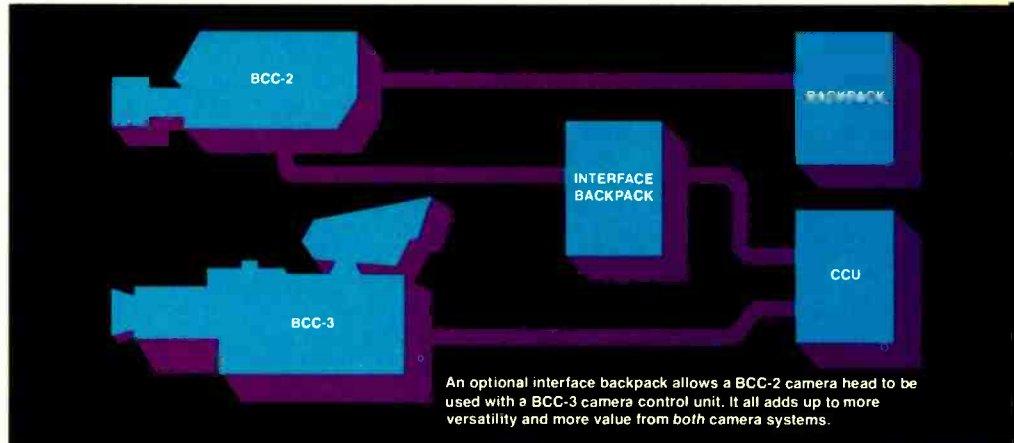

BCC-2 Portable Color Camera

Designed and built like our VTRs, this hand-held ENG/Field camera puts out a studio quality picture, yet the camera head weighs less than 16 pounds, including tiltable viewfinder and lens.

It gives your on-air look a new dimension in quality—quality that comes from features like three 1" Plumbicon* tubes, including an extended red. High sensitivity. Automatic iris and color balance. Modular maintenance accessibility. And more.

You'll discover a new dimension in flexibility, too. Your operator is on the air, or tape, in 2 or 3 seconds from standby. He can work up to 1000 feet from the van, or hook into a portable VTR for complete, battery-operated mobility. Conveniently located camera controls put him in better command of the action.

Most important: you'll appreciate how BCC-2's versatility lets it pay for itself fast. Mount it on a tripod with an optional studio viewfinder, and you have an ideal all-around production camera, with a picture just as good as its big brothers.

In all aspects, BCC-2's performance is equal to that of full-size cameras. In concert with BCC-3, it can add depth to your camera system and help you handle many different production applications, indoors or out.



word in VTRs, d in camera versatility.

Complete camera systems in themselves, BCC-2 and BCC-3 "mate" to give budget minded broadcasters a new dimension in ENG/Field and studio production

Meet the first camera in its class to successfully combine high quality engineering with a long list of big camera features you don't find in comparably priced cameras.

BCC-3 is a studio camera system that delivers a top quality picture at a medium price. You'll get three 1" Plumbicon* tubes, including an extended red. A unique optical system that cuts lag by 50%. Excellent registration. Superb signal to noise ratio. Adjustable masking to insure precise colorimetry match between cameras. Maintenance accessibility. And construction so rugged you can take BCC-3 out of the studio on location with complete confidence.

Also, you can integrate the BCC-2 portable camera into the BCC-3 system with an optional interface backpack. It ties BCC-2 to the CCU of the BCC-3, transforming a portable backpack recording unit into a versatile, sophisticated on-line camera. You'll enjoy the kind of picture control only a CCU can give—whether you're doing studio, field, or sports production.

If you're a budget-minded broadcaster, this new Ampex "building-block" team of BCC-3 and BCC-2 gives you unprecedented quality and flexibility. You'll get superb studio or remote production, true ENG/Field capability, and a high quality broadcast picture throughout.

All in step with any broadcaster's budget. For a demonstration, call your Ampex Broadcast Sales Engineer, or write: Ampex Corporation, Audio-Video Systems Division, 401 Broadway, Redwood City, California 94063.

*Trademark N.V. Philips

BCC-3 Color Studio Camera



AMPEX

Circle 120 on Reader Service Card

GREAT IDEA CONTEST FINALISTS

Pick three Panasonic color TV set and seven AM-FM clock radio winners by voting for the best Great Idea of 1975. Simply tell us on the Reader Service Card ballot which ideas you think most deserving in each of the three categories: AM, FM & TV. Top vote getters in each of the three categories win the top prizes, the TV sets.

Presented below in three categories are eleven finalists from the 45 Great Ideas which appeared in BM/E in 1975. These ideas scored the best in their respective categories. There are five Ideas from AM station broadcasters, three from FM and three from TV. We now want you to pick the best from each of these categories. The gentlemen whose Ideas score the highest in each of the categories will receive a Panasonic nineteen inch color TV set.

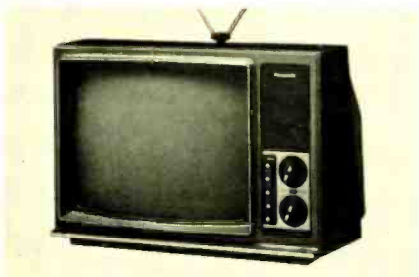

Three Panasonic TV set prizes.

Your vote will help determine who gets the Panasonic AM-FM radios. The clock radio winners will be those whose Idea received the greatest votes in each of the following categories

(after excluding TV set winners): 1. Control circuit Ideas from AM stations; 2. Audio Ideas from AM stations; 3. RF Ideas from AM stations; 4. Control Ideas from FM stations; 5. Audio Ideas from FM stations; 6. Control Ideas from TV stations; 7. Video Ideas from TV stations. (There were no RF entries in either the FM or TV category and no audio entries for TV.)

When entries are classified by sub-categories the following entries, though not in contention for a top prize, are in consideration for the AM-FM clock radios:

AM(RF): A Low Cost Bi-Level Modulation Modification by David Hebert, KXRO (May entry #8); FM (Control): Modified Cart Integrates Network News Into Auto Format by Vern Argo, KYLT-FM (June entry #5); TV (Video) Emergency Replacement For Dead Color Channel by William Gramling, WRC-TV (October entry #32).

All winners will be announced in the March 1976 issue.

BM/E thanks every broadcaster who took the time to enter the contest. In announcing the contest back in December of 1974 we wrote: "The col-



Seven Panasonic radio prizes.

lective ingenuity of station engineering personnel is a massive technical resource of the industry which is to a harmful degree unused. The tremendous reservoir of techniques accumulated in solving day-to-day problems, in making needed changes or improvements in facilities, and in designing new facilities, gets poor distribution through the industry because there are few channels for disseminating it." We believe the Great Idea Contest has helped in the disseminating of the ideas. Many of you readers have told us the Great Idea Contest is the greatest and that we should keep it up. We will, starting with the March issue.

Finally, we want to thank those who voted during the months. You have shown that good ideas, however unsophisticated they may be, are valuable and needed. Right now review the finalists and vote for your choice.

AM RADIO

1. Waveform Generator Synthesizes Steady-State Tones.

Jerry E. Shepherd, Transmitter Engineer, KCPX, Salt Lake City, Utah

Problem: To duplicate sound by artificially generating its characteristic waveshape. I developed a circuit which allows the user to obtain a signal which can be adjusted to any desired waveshape. The circuit was developed to fill a need for a combination test signal generator, digital-to-analog converter, and an AM or FM modulator.

Solution: The circuit divides the period of the input signal into 16 segments. By means of the 16 control pots, the user can adjust the amplitude of each segment to the desired amplitude while observing the output signal on an oscilloscope. If a dual-trace scope is used, it is possible to match the reference waveform very closely.

A square wave is applied to the input of a SN7493 binary counter connected to count from 0 to 15 in 16

continued on page 30

Kodak salutes the NPPA "Newsfilm Station of the Year"



Left to right: Ernie Schultz, Information Director and anchorman for the noon news, Gene Allen, Assignment Editor, Jack Ogle, News Director and anchorman 6 P.M. news, and George Tomek, anchorman 10 P.M. news.

This is the heart of WKY-TV.

For the second time in seven years, WKY-TV's newsfilm department has broken the bank. Oklahoma City's Channel 4 was again named "Newsfilm Station of the Year" at the National Press Photographer's Association (NPPA). This time, for 1975.

Featuring locally originated film from all over Oklahoma, the station broadcasts three half-hour news reports a day, with three 5-minute news breaks as well. When that news is gathered, the camera crews come out shooting, with four

CP-16 cameras. And Kodak Ektachrome EF film 7242 (tungsten).

And this is the backbone.

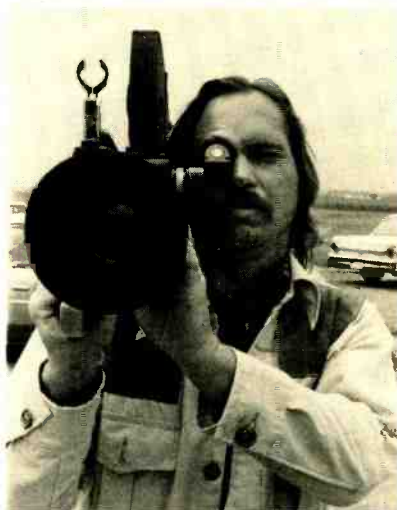

Darrell Barton, chief photographer.

Without good people like this, Channel 4 could be just another spot on the dial. Take Darrell Barton, 1974's "Newsfilm Cameraman of the Year." Or Director of Information Ernie Schultz.

"We have a strong commitment to telling local stories in depth on film," says Schultz. "We'd rather tell four good stories than have eight talking heads." This philosophy pays off. WKY-TV News won six out of nine Associated Press awards for superior reporting this year. All of them are trained to originate newsfilm, and most of them carry portable cameras.

Where do they stand on ENG?

"There are some real benefits in seeing appropriate stories as they are happening," says Schultz. "But we think the audience would become bored quickly if we tried to give that kind of urgency to most stories."

Good film. Good people. The best reporting. That's what we call good news.

Film. The Basic Medium.



Circle 121 on Reader Service Card

FIDELIPAC[®]

ACCESSORIES & CARTRIDGES

CART-A-ROUND CARTRIDGE STORAGE RACKS

Each WR-25 Modular Rack holds 25 Type A Cartridges . . . eight can be mounted on our Mobile Carousel Base to make up the MR-200.

WR-25 \$13.25
MR-200 \$145.95

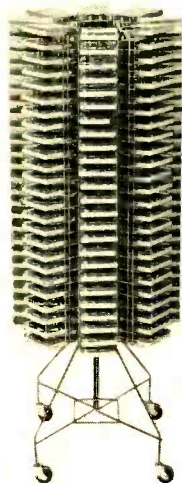

TABLE TOP CARTRIDGE RACK

Model TR-96 holds 96 Type A cartridges, Model TR-48 holds 48.
TR-96 \$73.85
TR-48 \$38.55



STUDIO ON AIR LIGHT

brilliant red lettering on jet black background can be seen even in the brightest ambient light conditions. \$29.95



CART-E-RASE DEMAGNETIZER

can be used for erasing cartridges, reel-to-reel tape, film sound stripping, etc. \$34.50

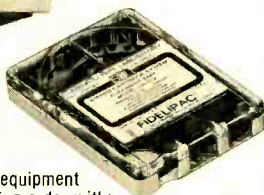

ALIGNMENT PROBLEM?

Keep your cart equipment in perfect working order with:

- 350 STA Alignment Cartridge \$38.50
- 350 STF Wow and Flutter Cartridge \$24.50
- 350 STQ Cue Test Cartridge \$35.00
- Head Insertion Gage \$3.35
- Height Gage \$12.95
- Right Angle Zenith Gage \$21.75



Contact your Fidelipac Distributor or

FIDELIPAC[®]

109 Gaither Drive, Mt. Laurel, NJ 08057
(609) 235-3511

® Trademark

Circle 122 on Reader Service Card

GREAT IDEAS

steps. As the counter proceeds through the 16 counts, its status is transferred to a SN74154 4-line to 16-line demultiplexer. The SN74154 has 16 separate output lines; with each of the states of the counter the corresponding output line is grounded while the remaining lines remain at a high level. As the input pulses arrive at the input of the chip, and the counter advances, each successive output line is grounded in turn. Each potentiometer is momentarily connected in series with resistor R1 while the remaining ones are floating and isolated from the circuit.

Resistor R1, connected in series with the potentiometer which is grounded at any given instant, forms a voltage divider. The value of voltage at point A is determined by the setting of the respective potentiometer. Since each of the pots is selected in turn, the voltage at point A continually varies

through each complete sweep of the signal. Since the circuit continues this operation until the input signal is removed, a signal of the desired waveshape is generated.

The output frequency of the generated waveshape is 1/16 of the frequency of the input signal. It is necessary therefore to apply a signal 16 times the desired output frequency to the input.

Capacitor C1 is used to block DC. Capacitor C2 is used if a step-type signal is not required and a smooth-changing waveform is required.

Amplitude modulation can be obtained from the circuit by replacing the 15 VDC with a sinewave of appropriate amplitude and frequency. In this case the sinewave signal will be amplitude-modulated with a waveshape determined by the setting of the controls.

Frequency modulation can be obtained by applying the output signal to a voltage-controlled-oscillator. The frequency of the oscillator will then swing in a manner determined by the setting of the pots.

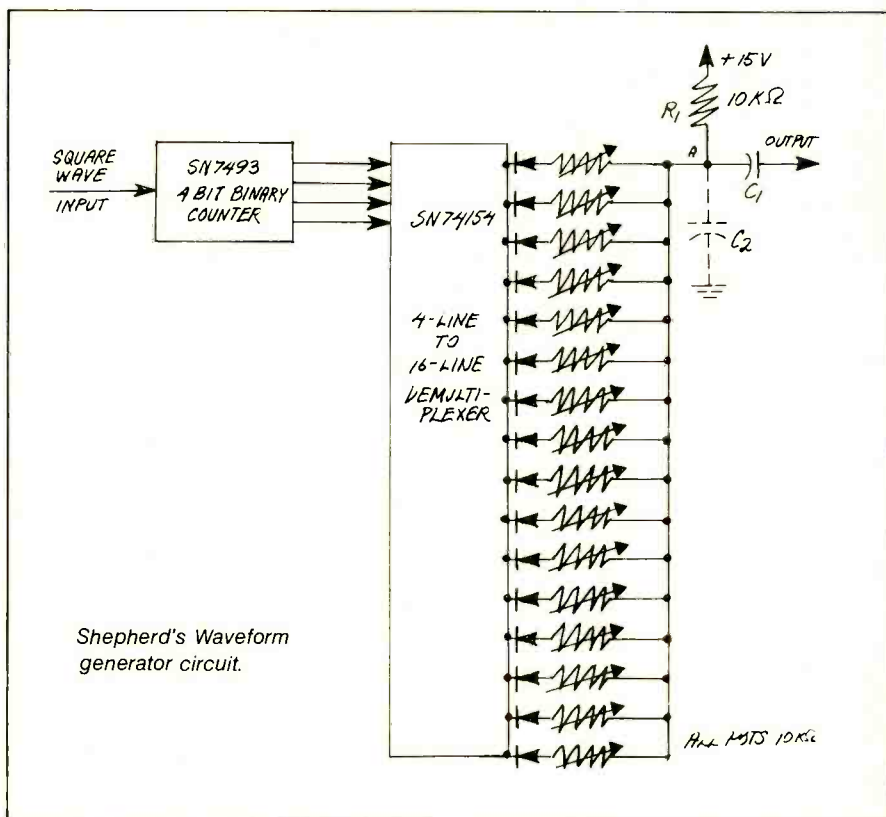

2. Telephone Dialer Eliminates Need For Separate Phone at Remote

Steven Terhaar, Chief Engineer,
KVOX-AM, Moorhead, Minn.

Problem: To carry a telephone alone with remote mixer, and inter-

connect when using regular dial-out phone lines for remote broadcasts.

Solution: We eliminated the need to lease a telephone coupler and telephone by just building the telephone into (or, in this case, onto) the microphone mixer. The mixer is used for two-way conversation before and during the remote broadcast. The talk-back is amplified by the headphone amplifier in the mixer by push-

ing a DPDT momentary-action switch. In this case, a Sparta RA-4 was used because it has a separate headphone amplifier. A neon lamp, placed across the phone line, works as a ring indicator. The coupler and telephone holding coil is made from a Triad

A67J transformer, which gives much better quality than a telephone in parallel with the line used for broadcast. The dial is taken from an old phone and the normally-closed contacts are used.

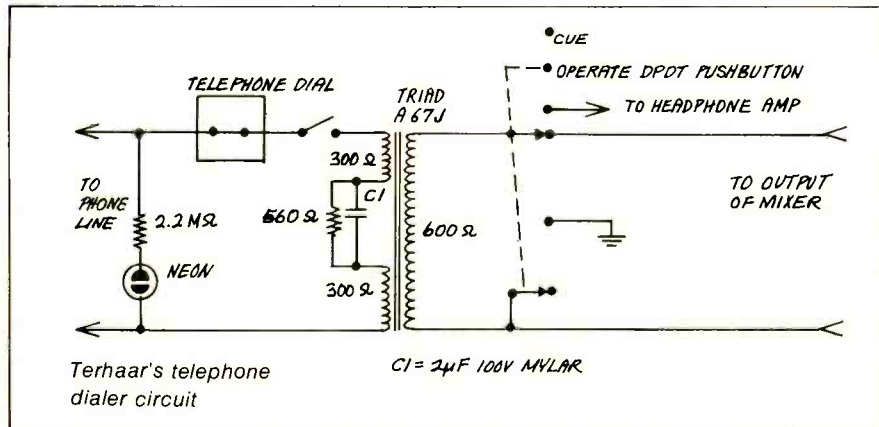

3. Dubbing to Previously Recorded Cart Without Adding "Stop" Cue.

Tom Hayes, Engineer, WGIV-AM, Charlotte, N.C.

Problem: To edit audio cuts and add material on previously recorded carts without adding Stop Cue tones. Ordinary modification of Gates ATC gear requires modifying the recorded 1 kHz stop tone. Some stations, to our knowledge, make the modifications with two switches and two buttons to switch, requiring an octopus or very agile set of arms to make this work.

Solution: Stopping the cart at the

end of the previously recorded material, and punching the Record Set button sets things up. Pushing the Aux Cue button both nullifies the addition of a 1 kHz tone, and starts the machine. Remote control is also now simpler to achieve. This feature can only be activated with the recorder on, so there are fewer problems with accidents.

Changes that an engineer might forget:

- (1) remove the jumper on pins 6 and 8 of remote control connector and put wire from pin 8 to pin 6;
- (2) move indicator light (+) lead to anode of diode;
- (3) remove C904, the Aux tone coupling capacitor.

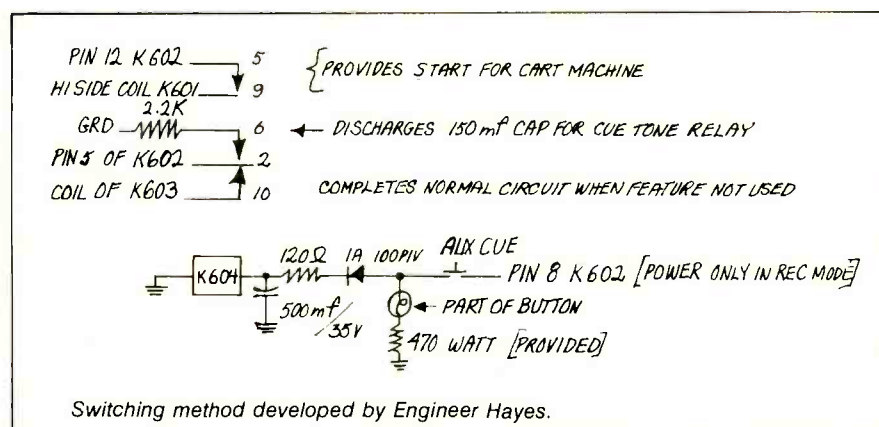

4. An Inexpensive Set-and-Forget Phone Patch

J.H. Wiegman, Chief Engineer, KWAL, Osburn, Idaho

Problem: To wire a telephone into a radio station in such a way that distant and local audio levels are nearly the same. Do so without buying an automatic gain controller. And wire it in such a way that it is impossible for anyone to forget to disconnect when

continued on page 32

CDL/DA's

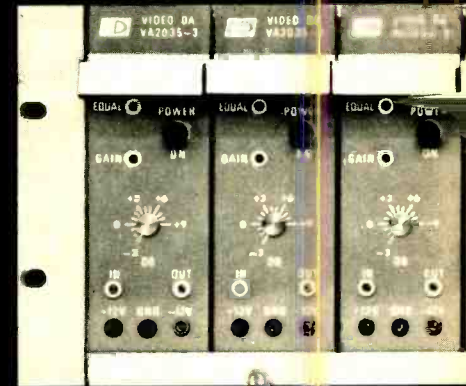

* shown

VIDEO EQUALIZING* PULSE

Specifications

- So good they have been the "standard equipment" in a major Network for 8 years.

Flexibility

- Electrically and Mechanically interchangeable
- 6 outputs
- Loop through input

Reliability

- Self-Powered
- Drift-free operation
- Thousands in use today throughout the world.

Rugged

- Extruded milled aluminum housing with stainless cover.
- Mount in rugged frames: 10 DA's per 3 RU frame and 3 DA's per 1 RU frame.

Price

- Superior performance and quality at competitive prices.

Availability

- Stock to 30 days.

For immediate additional information call:

Canada: 514-697-0811
U.S.A. (N.J.): 201-767-1300
Chicago: 312-991-4720
Los Angeles: 213-789-0574



CENTRAL DYNAMICS LTD

A PRECISION DEMODULATOR

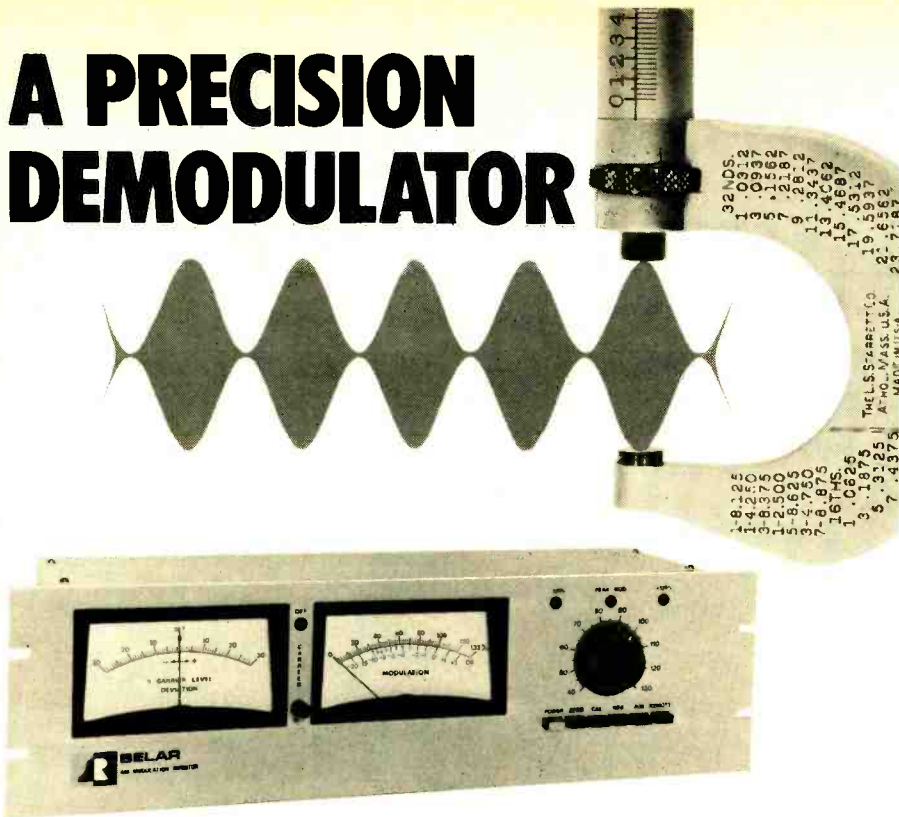

The AMM-2 AM Modulation Monitor

- RF frequency range — 200 kHz to 160 MHz
- 100% negative peak modulation light — independent of input carrier level
- 125% positive peak modulation light — independent of input carrier level
- Peak modulation light adjustable from 40 to 130%, calibrated in 1% increments — independent of input carrier level
- True peak reading modulation meter — responds to shortest duration program peaks
- Carrier level meter — indicates true carrier shift
- Phase-linear filter — no overshoots from clipped modulation peaks
- Remote outputs — outputs for both meters and peak lights
- Built-in modulation calibration
- Built-in carrier-off alarm
- Outputs for listening as well as test functions
- 115/230 volts, 50/60 Hz operation
- FCC Type Approved

The AMM-2 Modulation Monitor sets new standards in accurate AM monitoring — the first AM monitor to incorporate true ratio-type peak indicators. The AMM-2 contains a unique modulation cancellation scheme to recover unmodulated carrier to reference the modulation peaks to. Thus the instantaneous program peaks are referenced to the instantaneous carrier without the need of time-constants, as with AGC devices. True carrier is indicated even with the asymmetrical modulation encountered in today's high positive peak modulation, and the peaks are automatically referenced to this true carrier to give the most accurate indication of program peaks.

The AMM-2 incorporates a phase-linear filter that does not produce overshoots when a negative peak clipper is used in the transmitter. The true modulation peak is measured instead of a false, higher peak introduced by the non-linear phase filters found in other monitors.

With the AMM-2, you can turn up your level to where it belongs for maximum loudness.

\$850 DELIVERY FROM STOCK

There are well over 3000 Belar AM, FM and TV monitors currently in use worldwide.



BELAR
ELECTRONICS LABORATORY, INC.

LANCASTER AVENUE AT DORSET, DEVON, PA. 19333 • BOX 826 • (215) 687-5550

Where Accuracy Counts . . . Count on Belar

Circle 124 on Reader Service Card

GREAT IDEAS

the call is done.

Solution: Many telephones (all those made by Automatic Electric) have a transformer circuit which phases out the microphone at the earphone. All you have to do is pick off the audio for your programming at the earphone. The outgoing signal (your phone mike) is attenuated at this point, so that even with a long distance call, both the near and far voice will be about the same level. In our situation, this system has worked well, especially where we have been recording. The usual vast difference in levels between the two sides of a phone conversation are too hard to compensate for manually; an AGC would cause some pumping and costs too much. But with this hookup, when you hang up the phone, the line hangs up as well. No need to disconnect your recorder or console from the line. Line isolation is provided by a scrapped radio audio output transformer. The high-impedance side goes to the earphone. No pad is needed, and clicks and pops are nil.

5. Visual Indication Of Cart Status For Board Operator

James H. Young, Chief Engineer, KTAN-FM-AM, Sierra Vista, Arizona

Problem: Our Tapecaster cart machines are located to the right of the operator not readily visible when looking toward the live-copy book in front of him. Consequently there is some confusion as to which cart to start following a live announcement.

Solution: An SCR and an illuminated pushbutton remote start switch were added to each of our 3 Tapecaster X-700 cart playbacks. The switches are mounted immediately in front of the operator and are illuminated whenever a cart is loaded, ready to play, but are extinguished if there is no cart in the machine or if that cart has already been played.

The remote start button is not defeated, so the machine can be restarted for a donut spot if desired. However, this circuit could be adapted to absolutely prevent restarting.

The circuit has been used with Tapecaster equipment only, but it should be adaptable to other brands. The SCR is activated when 24 Volts are applied to the anode as the cart is inserted into the machine. A pulse is coupled to the gate and the SCR

GREAT IDEAS

good isolation between sources. The values of input and output capacitors shape low-end response. The 47 ohm resistor at pin 6 of the 709 IC prevents spurious oscillations. Each amp operates with -10 VU in and out.

The normal operation has the selector switch pre-set so the turntable preamp feeds directly to an input of the Gateway console. This input is normally in Cue mode. After cueing a record, the switch is set to stereo, and the output brought up via the dual pots. We have only three stereo sources at present, but more can be added to the IC amp.

A pc board holds everything down. The amplifiers, power supply, etc. fit into a 19-in. enclosure. Our total expenses to go stereo: less than \$1500.

7. \$15 Audio Frequency Counter

Michael E. Marion, WTFM-FM, Fresh Meadows, N.Y.

Problem: To build a very low cost audio frequency counter. Using in-continued on page 36

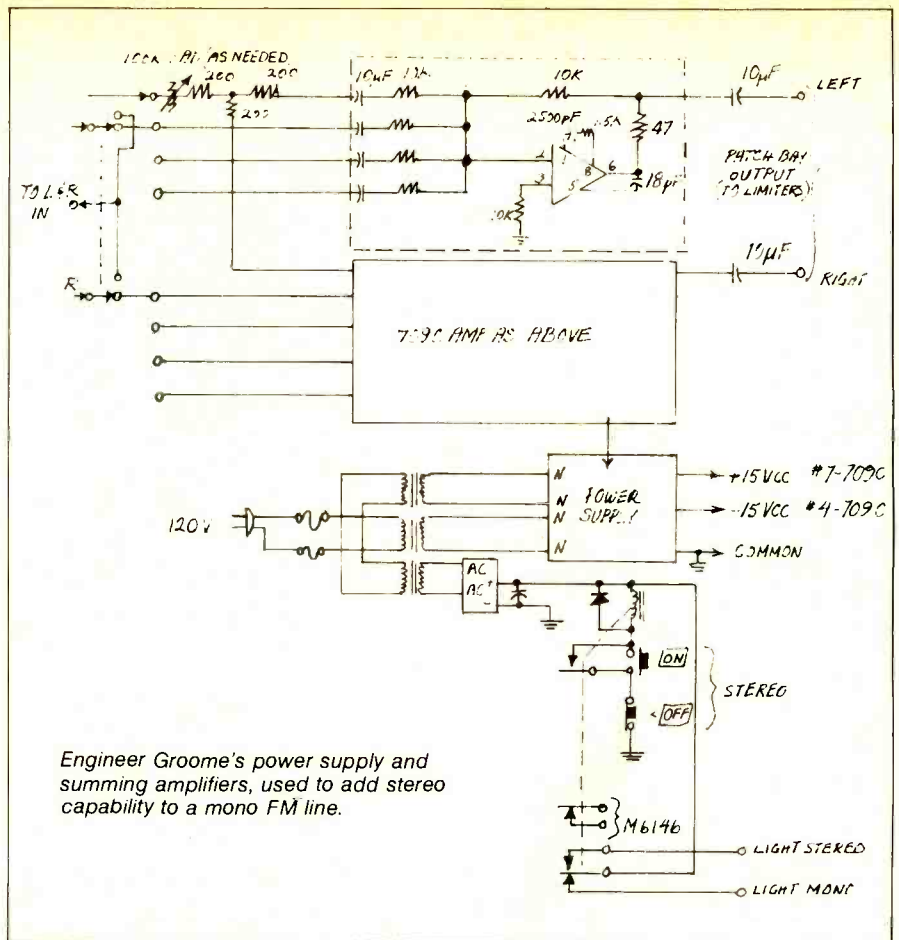

PROFESSIONALS SPECIALIZE

MODEL 367 SMPTEmat Switcher

- Color Switcher
- Color NTSC Genlock Sync Generator
- SMPTE Edit Code Reader/Generator
- Interface Panel

Post Production Switcher

▼ \$3,500 List

CHROMATIC DUET

▲ \$4,320 List

MODEL 370

Special Effects Generator

- 10 Basic Wipe Patterns
- Dissolve to Effects
- Built-in Color Background Generator
- Over 1000 Units Sold

Production Switcher

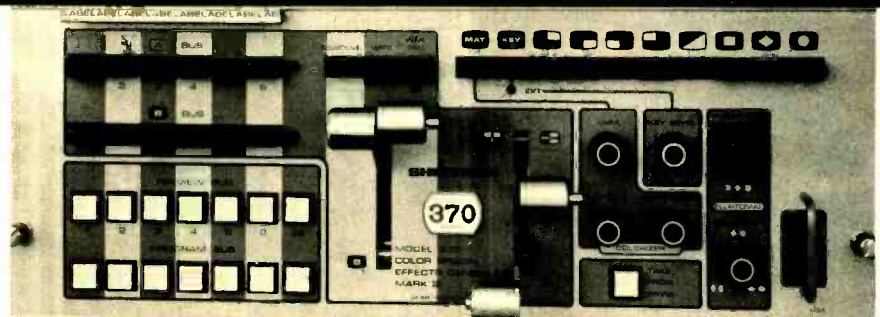

SHINTRON
Cambridge, MA 02142 (617)491-8700

... The Precision People

Circle 126 on Reader Service Card

AKAI RELIEVES BACK PAIN.

One of the common discomforts due to excessive videotaping is back pain.

Lugging around those 35 and 40 pound VTRs through crowds, down stairways, up stairways, up hills, steep hills.

Well, no more. Akai has a remedy — our new VTS-150B we call the Hustler.

The Hustler doesn't weigh 35 or 40 pounds like other recording units. It doesn't weigh half that.

In fact, it doesn't even

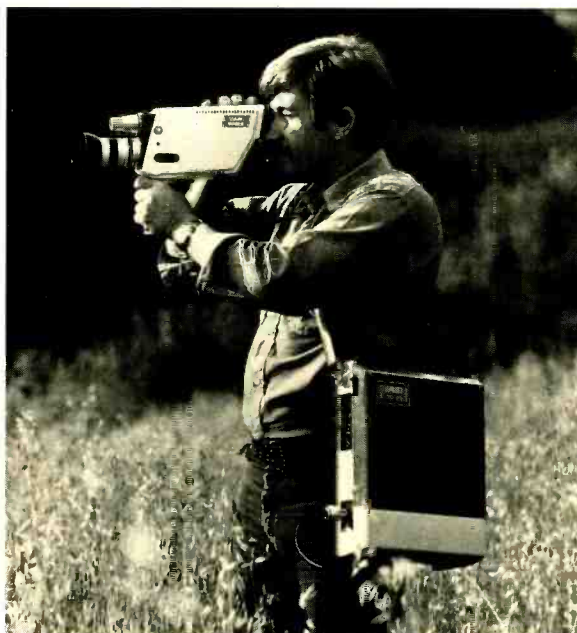

need to go on your back.

The Hustler is a 16 pound color videotape recorder you sling over your shoulder, and a 6 pound color camera you can carry in one hand.

No wonder 63 TV stations are now using our little Hustler.

The lightweight, two-piece, one-man operation that isn't a pain in the back — or anyplace else.

AKAI™

2139 E. Del Amo Blvd., Compton, Ca 90220

Circle 127 on Reader Service Card



RCA broadcast service performing over 35 years behind the scenes

Broadcasters' repair, modification, and overhaul needs are strictly behind the scenes. And RCA Service Company experts keep on providing service to keep all your broadcast equipment operating at peak performance. Take advantage of RCA's experience in AM, FM & TV servicing — on a contract or per-call basis. Dial either of these offices for full information about fast, dependable RCA service: Chicago (312) 298-7980 Philadelphia (215) 467-3300 If you prefer, contact: RCA Service Company A Division of RCA Technical Services, Bldg. 204-2, Camden, N.J. 08101 Phone: (609) 779-4129



Circle 128 on Reader Service Card

GREAT IDEAS

expensive TTL logic IC's, I built a frequency counter with a three-digit LED readout, usable to 99.9 kHz. By purchasing the parts surplus, I kept total cost to \$15.

Solution: The circuit basically consists of three decade counters connected in series to give a three-digit readout capability. Each decade counter (SN 7490) is connected to a quad storage latch (SN 7475) which is in turn connected to a LED driver (SN 7448) to drive a seven-segment common cathode LED (such as the MAN 3). The input of the counter/display section is fed by an SN 7402 quad NOR gate which has three of the NOR gates connected to form an AND gate. The fourth gate is unused.

One input of the AND gate (+ out only if both inputs are +) is fed by an SN 74121 monostable pulse generator. By delivering a fixed interval positive pulse, it keeps the AND gate open for this specific interval. The time interval is selected by the values of R and C connected to the SN 74121. The other input of the AND gate is fed by the Schmitt trigger (SN 7413) which conditions the signal to be counted, by which it is fed.

Two of the six inverters in the hex inverter (SN 7404) are connected to form a flip-flop which serves as a bounce-less pushbutton trigger for the 74121. Depending on the values of R and C, the counter will count the input pulses for 1 sec., 0.1 sec., or 0.01 sec. The frequency counter uses a well regulated 5 Vdc power supply, and draws about 0.5 A.

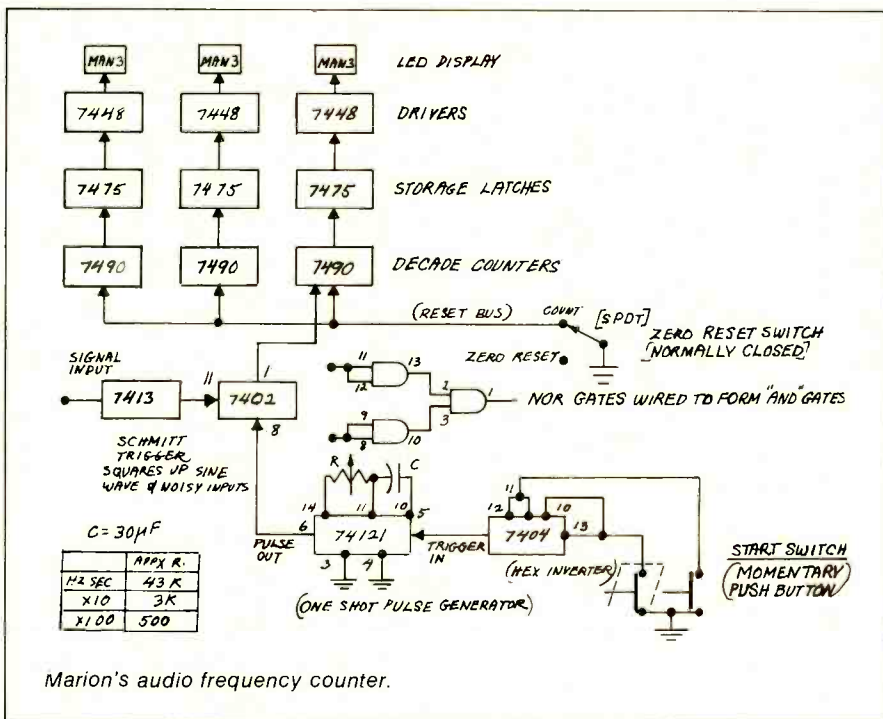

8. Novel Control Circuit Needs No Common Bus.

Jeremy R. Burnham, Engineer,
KKDJ-FM, Hollywood, Calif.

Problem: To use a single-pole momentary-contact pushbutton switch to remote-start cartridge machines and reset a common digital electronic clock in a situation where no ground or common bus can be used.

Solution: Series diodes are placed on both sides of the pushbutton switches in both the clock and cart machine circuits, with proper polarity to isolate the two circuits from each other. The clock floats with respect to

ground because of its internal power transformer. It makes no difference if either side of the cart machine circuitry sees a ground.

For simplicity, the clock re-set and the cart machine remote start circuits have been re-drawn with their equivalents. The circuit is easily understood when we realize that, with the switch open, no current flows in either circuit. When a button is pressed, current flows in both the clock and cart machine circuits independently. Since the two circuits are effectively coupled at only one point, there is no interaction between the two whatsoever. Any number of machines using any combination of direct current control voltages can be connected in this manner, and any number of buttons

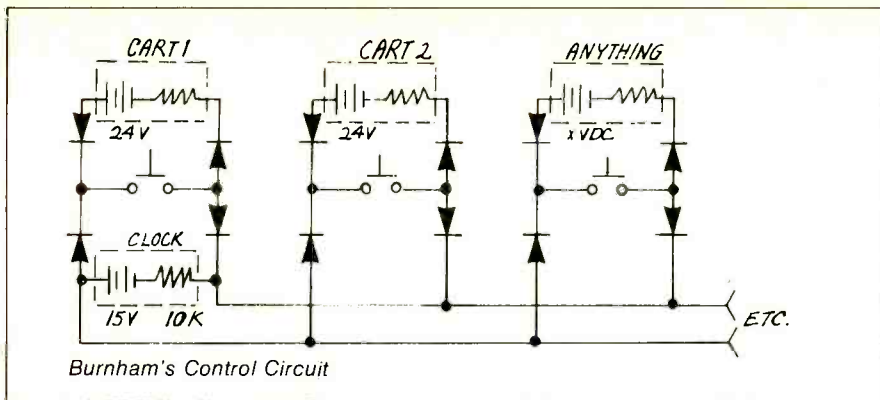

test chart that they pick-up the reflected light from completely different angles. Studio lighting as well as ordinary illumination transmits various degrees of color temperature. Therefore, the reflected light picked up by cameras at different angles "see" different color temperatures, depending upon which light is being reflected by the test chart into each camera lens. This makes a two or three camera match almost impossible.

Solution: We built a relatively simple beam-splitter box using op-

continued on page 38

may be pressed simultaneously. KKDJ employs a Heathkit GC-1005 digital clock inexpensively modified to re-set to zero, coupled to six ITC cart machines, and controlled with touch switches.

TV

9. Simple Beam-Splitter For Accurate Color Matching

Myles H. Marks, Engineer, WIIC-TV, Pittsburg, Pennsylvania

Problem: Matching color studio cameras using a logarithmic "chip-chart" is, at best, a very difficult and tedious task especially in small studios where the cameras are so close to the

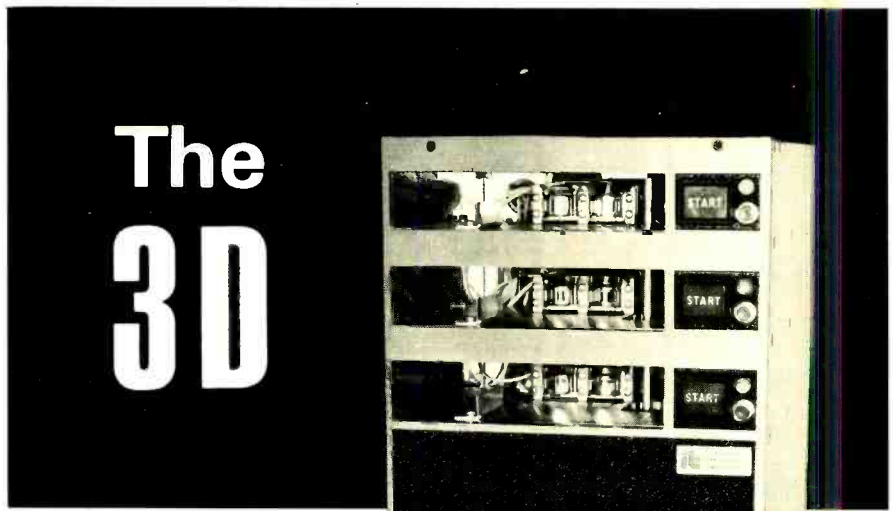
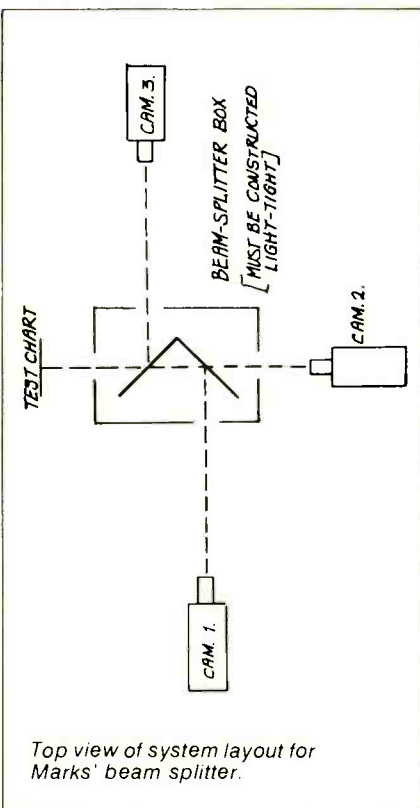

The 3D

Three reliable ITC decks in a space-saving common housing.

- **Compact** — three decks convenient to the operator in the space of two single deck machines.
- **Individual** — decks operate independently with separate audio output and remote control.
- **Versatile** — multi-tone machines may be readily adapted so each deck automatically starts the next.
- **Economical** — three premium line reproducers for little more than the price of two single deck units.
- **Rugged** — decks are 1/2 inch thick hardened aluminum to insure stability.
- **Quiet** — guaranteed by ITC's air-damped solenoids.
- **Serviceable** — simple, reliable mechanics easily accessible through a hinged front panel and slide-out decks.
- **Record** — add a WRA Recording Amplifier and convert the bottom deck to a Master Recorder / Reproducer.

Put the 3D to work in your station. Pick up the phone and call ITC collect (309-828-1381). Ask about our 30 Day Guarantee of Satisfaction.



INTERNATIONAL TAPETRONICS CORPORATION

Marketed exclusively in Canada by McCurdy Radio Industries, Toronto, Ontario, Canada

Circle 129 on Reader Service Card

©1975 by ITC

SERIES 5000

from
Spotmaster®

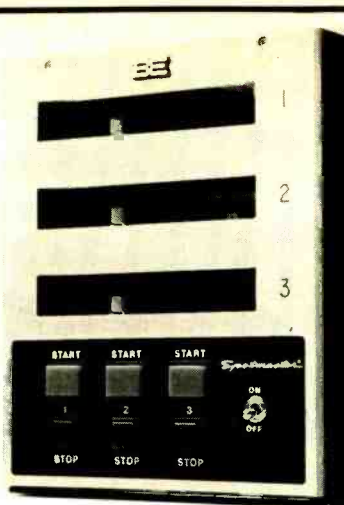

Versatile, accessible and reliable describes the new 5000 Series multi-deck cartridge reproducer from SPOTMASTER. **Versatility** in design lets you choose from a three or five deck model in either mono or stereo, with or without cue tones, record and other options. **Accessibility** from fold down front panel and slide out deck plates for easy cleaning and adjustment of the PHASE LOK III head bracket, plus a completely removable electronics package with modular components and easy trouble shooting with LED indicators of front panel functions. **Reliability** means the use of the best switches and components available including ribbon cable to replace bulky multiple wire harnesses, massive machined deck plates, a direct drive hysteresis synchronous motor and a super silent air-damped solenoid.

It's all here in the new 5000 series. Call us for more information and a complete set of specifications.



BROADCAST ELECTRONICS, INC.
8810 Brookville Road, Silver Spring, Md. 20910
Phone + 301-588-4983

Circle 130 on Reader Service Card

The seventeen and one-half pound

CAT-KIT Quartz Location Lighting Kit

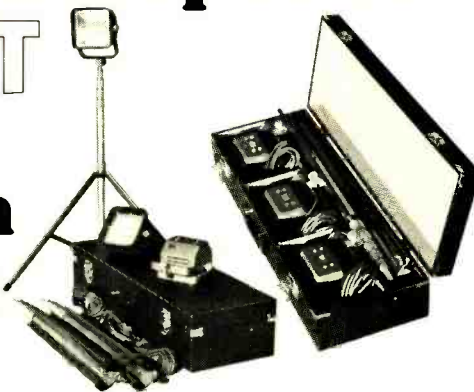

The CAT-KIT is ideal for CATV and for all on-location filming requiring an extremely compact and ultra-lightweight lighting kit.

For further information, please write to:

cinema E products
CORPORATION
Technology in the Service of Creativity
2037 Granville Avenue, Los Angeles, California 90025
Telephone: (213) 478-0711 ■ Telex: 69-1339 ■ Cable: Cinedevco

The CAT-KIT, which weighs only 17 lbs., 8 oz., includes: three non-focusing fill lights (*miniature broods*); three 10 ft. long three-wire cables (with in-line switches and parallel blade U-ground plugs); three "POP" light stands (made of aluminum); and a sturdy carrying case, measuring

only 5¾" x 9½" x 27". The CAT-KIT operates at 120-volts AC/DC with 650-watt double-ended quartz lamps.

Circle 131 on Reader Service Card

GREAT IDEAS

tically transparent glass plates as the mirrors. Using this it is possible for as many as three cameras to "see" exactly the same reflected light at exactly the same angle and thus exactly the same color temperature. (See diagram) The dimensions of the beam-splitter box will depend on the distance between the test chart and the box: the shorter the distance, the larger the box must be. When all cameras "see" the same reflected light, a much better color match can be made than with normal side-by-side alignments and balances.

10. Interphone Power Regulator Offers Wet & Dry Outputs.

*David F. Miller, Design Engineer
WMAQ-TV, Chicago, Ill.*

Problem: To regulate the input power to a transistor interphone amplifier, regardless of line voltage fluctuation or power demand. Many of the new transistor interphone amplifiers specify a maximum input of 15 VDC to the L1/L2 input terminals. Most stations power these amplifiers through the 24 V plant battery, dropping the voltage via a high-resistance retard coil. But depending on the ohmic value of the coil, and how many amplifiers are on the system, the voltage at the L1/L2 terminals can vary greatly.

Solution: The circuit shown automatically regulates interphone feed voltage to 15 VDC maximum, regardless of variations in plant battery input and output load conditions. The regulator IC shown employs internal current limiting and thermal shut-down, making it virtually short-circuit and blow-out proof.

Two conditions, however, must be protected against: reversed polarity at the input, and application of a foreign DC voltage at the output of the chip. To cover these cases, a diode steers only the correct polarity to the input, and interphone system output coupling is through capacitors ("dry" or audio-only output). Dry coupling is the preferred method of linking stations in the system together anyway; I²R losses are eliminated, and relay and switch contacts are preserved.

The two chokes shown act as retard coils to audio, but have very little DC resistance (32 ohms) and so maintain the DC regulation under various loads. Chokes of one ohm resistance are

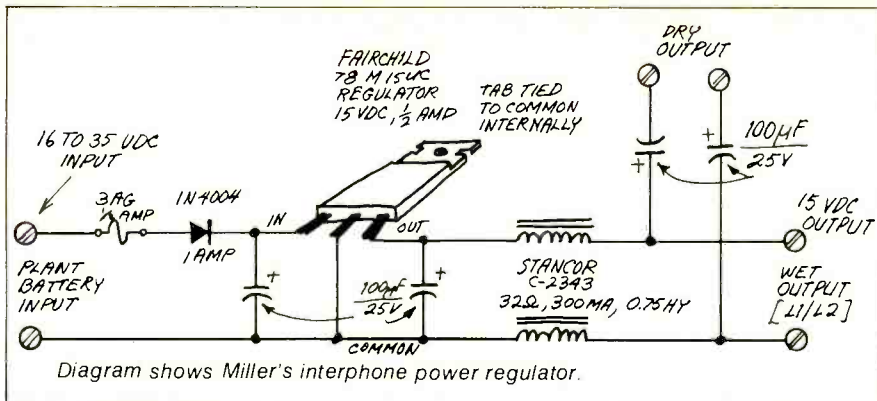

sensed, the projector stops. The -12 volts obtained from K111 (cue defeat relay) is removed; K1 drops out, and the circuit resets itself.

The local state indicator lights (I1, I2 and I4) are mounted in the bypass switch, and are intended to indicate the state of the relays and to expedite trouble shooting if it becomes necessary, as well as to serve as on/off indicators during operation.

The remote state indicator lights (I3 and I6) serve as on/off indicators only
continued on page 40

available at higher cost. The actual number of interphone amplifiers that can be powered by one regulator circuit depends on the DC current requirements of your amplifier. In our system, eight can be safely powered, but this number can be increased by a higher current IC and lower resistance chokes.

11. TP-66 Cueing System Modification.

Richard Kihn, Engineer,
KFDM-TV, Beaumont, Texas

Problem: To automate notification of director of news story endings without the use of visual cues.

Solution: Until the circuit modification was made, a man stood beside the TP-66 film projector and informed the director of approaching end-of-film. A cue at the head of each story stopped the projector, as the cueing system was designed to do.

With the modification system in use, a cue is placed seven seconds before the end of the news story, and another cue is placed on the film at the head of the next story.

When the seven-second-to-end cue is sensed, TB701-8 (to which the cue sensor was moved from TB701-7) is momentarily placed at ground potential, causing relay K1 to pull in. The sequence: Relay K1 contacts 11 and 7 to hold it in; contacts 9 and 5 turn the buzzer on; contacts 10 and 6 complete the ground circuit for the coil of K2.

The coil voltage for K2 starts to build up and reaches sufficient potential to pull K2 in. With values shown, this delay is about 1/3 second. This is sufficient time to allow the 1/4-inch wide cue tape to clear the cue sensor.

Relay K2 contacts 11 and 7, then connects TB701-7 to TB701-8, effectively putting the projector into the "normal" operating mode. Contacts 1 and 9 then cut the buzzer off.

When the start-of-next-story cue is

THE BROADCASTERS CASSETTE™

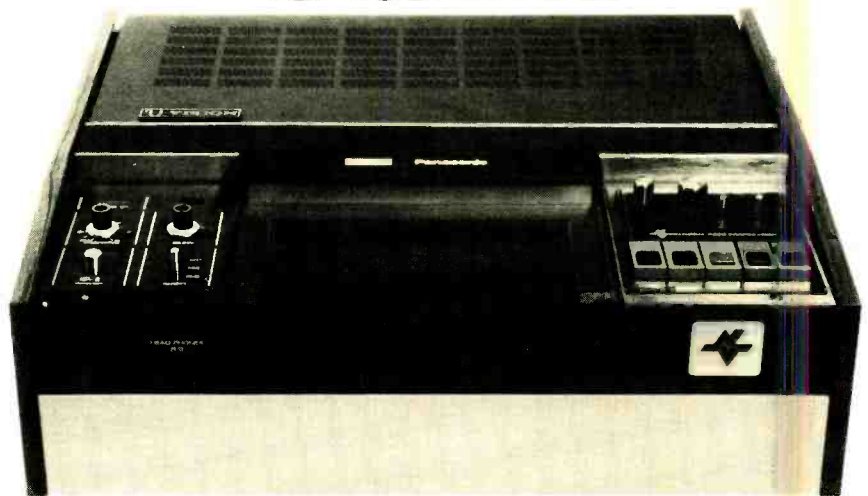

ON-THE-AIR DIRECT FROM 3/4-INCH CASSETTES FOR LESS THAN \$3000!

National Video has designed special video cassette players and recorders to work with the present state of the art time base correctors for broadcasting, duplicating or as editing source machines.

These capstan servo machines feature switchable external/internal 3.58 MHz operation allowing chroma correction in either direct or heterodyne modes. The capstan can be locked by advanced composite sync or by a one volt video signal. Variable speed slow motion is a standard feature and provides a range from still frame to near normal speed. All machine functions, including slow motion, can be remote controlled.

The BROADCASTERS' CASSETTE recorder SCR-1053* and player SCP-1052* are part of the PROFESSIONAL CASSETTE™ series of high performance editing and origination equipment from National Video. For more information contact us. For a demonstration see us in Booth 116 at the S.M.P.T.E. Conference Sept. 29—Oct. 2.

 **NATIONAL VIDEO CORPORATION**
840 West Glenoaks Boulevard, Glendale, California 91202

*Patents Pending

Circle 132 on Reader Service Card

new! self-cooled load package for AM/FM/TV/UHF

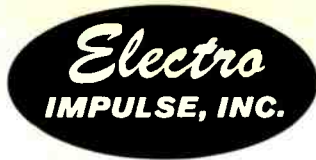

MODEL CPTC-30K

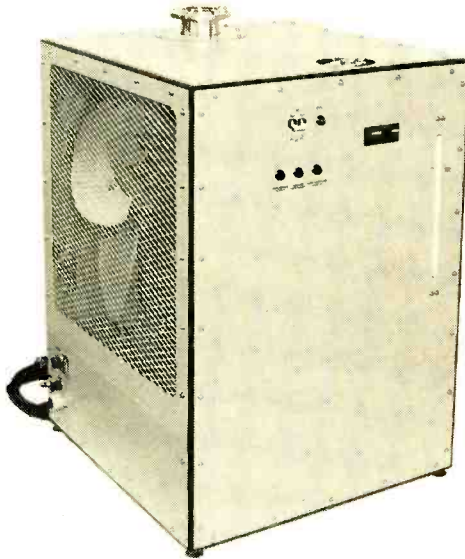

INPUT CONNECTOR
3/8" EIA

FOR 24 HOUR A DAY
CONTINUOUS USE!

40KW

CONTINUOUS AVERAGE
MAX. AMBIENT 85°F

30KW

CONTINUOUS AVERAGE
MAX. AMBIENT 105°F

Frequency Range/VSWR	
60Hz - 1GHz	1.1:1
1 - 1.5GHz	1.15:1
1.5 - 2.0GHz	1.20:1

- Consists of a highly reliable Water Cooled Load, Heat Exchanger, and Interlock System...ALL IN ONE COMPLETE PACKAGE!
- Exceptionally low IM distortion and temperature coefficient.
- Size: 35" H. x 24" W. x 25" D. 300 pounds.
- Requires 208/220 VAC, 1 Ph, 60Hz, 12 amps. (Export Model Avail.)
- Ultra-reliable design - Easily field maintained - Should never require factory service.
- Interlock system protects against low flow, high pressure, high temp., line power loss. Transmitter Relay Contacts provided.
- Resistor is FIELD Replaceable. One spare resistor is supplied with each unit. Extra resistors cost under \$100.00 each.
- Calorimeter feature available.
- WARRANTY - 25 MONTHS!
- Other models for 10 through 75KW available.

OUR 26th YEAR OF GROWTH

116 CHESTNUT STREET • RED BANK, N.J. 07701
PHONE: 201-741-0404

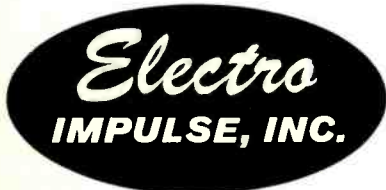

Circle 133 on Reader Service Card

GREAT IDEAS

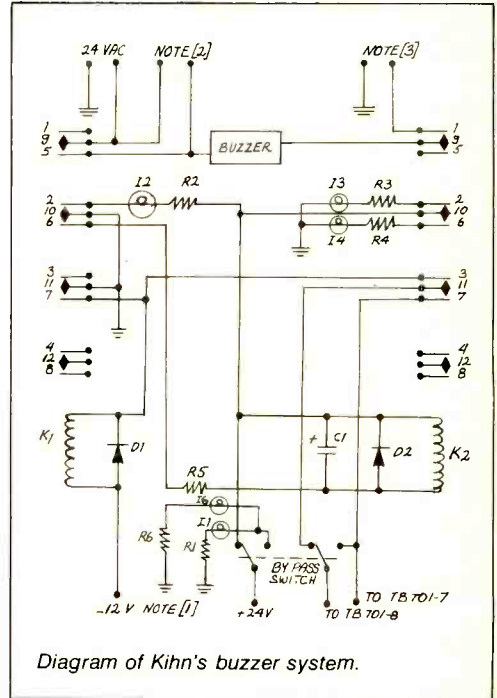

Diagram of Kihn's buzzer system.

for benefit of the director. Resistors R1, R4 and R6 are used to extend the life of the 327 lamps.

Separate buzzers could be used for each projector, but it was desirable to use the same buzzer for the complete system in our installation. Although designed for use on our projectors, this system should be adaptable to others.

Vote Now On Reader Service Card

Enter Now Great Idea Contest 1976 Win a calculator!

Tell us how you solved an annoying or time-wasting problem at your station. Gain professional recognition and become eligible for a prize at the same time. Three grand prizes will be awarded—a slide rule engineering calculator for the best idea from an AM station, FM station, and TV station. Ten secondary prizes consisting of pocket business calculators will be awarded in the categories of audio, video, control and RF. Rules same as last year.

Contest begins in March, 1976. Use entry form from last year or simply indicate type of station (AM, FM, TV) at which idea is used and category (audio, RF, video, control).

When you buy this Ikegami portable with the big new viewfinder, you get a great studio camera, too.

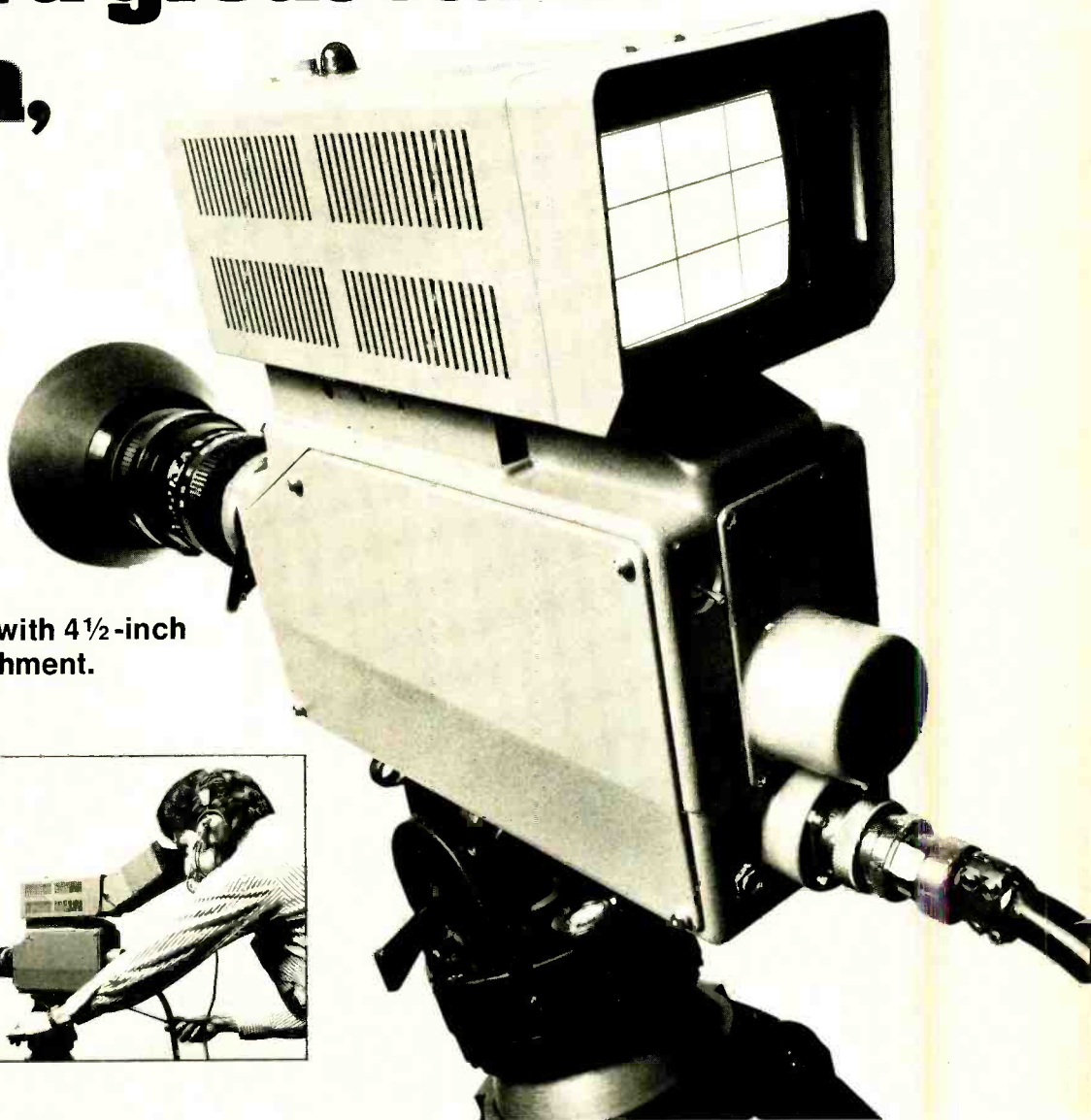

Now. The double-duty HL-33A1 color camera with 4½-inch studio viewfinder attachment.

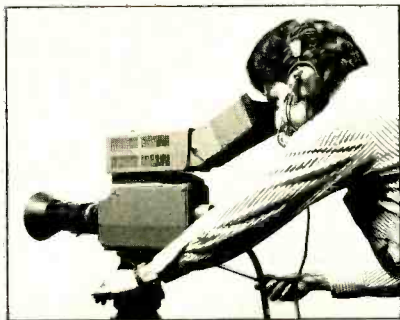

It's like having two cameras.

With the backpack and regular 1½-inch viewfinder and eyepiece, your rugged Ikegami HL-33A1 portable color camera handles the tough, fast-shooting field assignments.

Attach the new 4½-inch studio viewfinder, and you have the preci-

sion framing to handle any studio job. Sports remotes, too.

You get new improved optics for increased light sensitivity. Three Plumbicon* pick-up tubes for picture quality equal to the best big studio cameras. Variable speed power zoom. Matchless Ikegami dependability.

And now, total inside-outside convertability.

(Already own the HL-33 system? The studio viewfinder is available for your cameras.)

Call or write for a demonstration.

IKEGAMI
Depend on it

Ikegami Electronics (USA) Inc., 29-19 39th Avenue, Long Island City, New York 11101 (212) 932-2577

Circle 134 on Reader Service Card

PHILIPS

More Two-Tone EBS Systems

Since BM/E's December report on EBS systems the count has gone from 10 to 17. Prices are modest.

Shifting the whole industry to the new EBS two-tone signal promises to be far easier than anyone would have imagined three or four years ago.

The operation is getting a tremendous lift from recent sharp reductions in prices of CMOS IC's, and from advances in digital frequency division. These have made possible the ready design of modest-priced systems from many sources all meeting the FCC's tight specifications.

A general industry opinion that the FCC's narrow tolerances would be too costly was one of the factors that kept the specifications up in the air for so long. About a year ago there was evidently a significant break-through when the use of piezoelectric tuning forks for both encoding and decoding got widespread approval. Some of the units now available, as the list shows, do make use of such devices, and they apparently do the job with full satisfaction.

A majority of the makers, however, have chosen to use crystal-controlled oscillators at mega-frequencies for tone generation, with solid-state dividers to bring the frequencies down to the required 853 Hz and 960 Hz. This general approach appears to be something like a "standard." For decoding, some use filters with band centers established by the generated tones, others use phase-locked loop filters, etc.

But whatever the circuit system used, all units apparently come up to FCC specs with no sweat. Several of the makers have pointed out to BM/E that their respective units easily exceed the required limits: the technology is evidently widely available to do this, within the general price bracket that has emerged of about \$200 to about \$500 for a complete system.

How to choose?

This supplies the initial condition for successfully changing to the new signal, which for obvious reasons everybody has to do at the same time, now set at midnight of April 15th. Since every unit sold must have FCC approval, the buyer can be sure that any unit of a reliable manufacturer does obey the "rules."

Then how does he choose? Since we have no information yet on how any of these systems will stand up in use, the reputation of the maker may be the decisive factor for many buyers. On the other hand the near-standardization of general design suggests that any designer of real professional skill can turn out a proper system.

The prices do vary, but even the most expensive are low-priced items by most broadcast standards. Thus except for the very small stations, price will be some-

CORRECTION

In our December story on the EBS two-tone signal, we said (page 34): "The Defense Office of the FCC has drawn up a model EBS plan which can be used by State and local governments . . ." This should have read: "The Defense Civil Preparedness Agency, the National Weather Service, and the FCC, in cooperation with the Parkersburg, W. Va. operational area Emergency Communications Committee, have drawn up a model plan . . ." etc.

what less weighty than it is in the purchase of a console, transmitter, or antenna system. With a sharp time-crunch in effect, delivery time may be crucial for many.

Beyond those factors, there is some variation among the units in operating conveniences. Methods of connecting the encoder into the system, and the indicators and alarms included (beyond those required by the FCC), as shown on the list of units, may tip the scales for some buyers.

One favorite connection system is a "loop through" of the program line, passing through the encoder, with an internal relay that automatically disconnects the studio and connects the encoder when the start button is pushed, or in some cases also when an alert is received on the decoder. Another way of connecting the encoder is by bridging on the audio line; the regular program has to be turned off at the console. And a number simply have standard 600 ohm transformer coupled outputs for connection into the audio system in any way wanted.

Every encoder is required to have an indicator that shows when the encoder has been activated. Beyond that, a number include relays that can be used to operate an external alarm—a bell, light, or whatever—when the encoder is started.

Decoder alarm relays: a good idea

The main assignment of the decoder, to demute the monitoring receiver when the two tones come in together, is nearly always backed up by a non-required function: a relay for, again, an external alarm. Although the FCC didn't specify it such an alarm seems highly desirable, a judgment that nearly all the makers evidently agree with. Station managements will probably not want to depend entirely on a busy operator's hearing an alert on the monitor receiver for immediate knowledge of an EBS transmission.

The units differ in the way they indicate that a monitor signal is, indeed, being fed to the decoder input, in the "mute" mode. A "carrier-off" alarm does it for several; there are panel peak flashers for the carrier; or a "listen" button that will demute the receiver momentarily so the monitored station can be heard.

Highly convenient testing methods are almost universal. Usually a single switch or button will feed the encoder output directly to the decoder, for an operation check of both units. The two encoder tones are available at test points for level and distortion checks; individual faders are provided.

Finally, there are some differences in physical arrangement. There are integrated encoder/decoders, in single packages; there are many variations of separate packaging. Early last year the FCC specs made it desirable to have the encoder right at the transmitter (output had to modulate the transmitter to 40% \pm 5%). But the August revision, making this "at least 40%," removed this constraint: the encoder can be at the audio input, or at the transmitter.

A number of makers have optional radio receivers that

match the decoders physically and electrically, but in every case the decoder will also operate with any good receiver that has a specified minimum output level. Some of the specially designed radio receivers do have features—thumb-wheel crystal controlled tuning, push-button choice from two fixed channels—that could be valuable to the broadcaster.

As in the December issue, FCC approvals issued up to press time are indicated by asterisks in front of model numbers. More approvals are likely to come through after this magazine appears; if a unit you like does not have it here, check with the manufacturer (he'll be the first to know).

A List of Available EBS Two-Tone Signal Equipment

Maker	Model	Price
A.C. Radio Co., Pompano Beach, Fla.	* SG-12A Encoder	\$215.00
	* DA-21A Decoder	99.00
	Optional Internal AM rec'r for decoder	55.00

Encoder: Single crystal oscillator, divided down. Timing control by further division from 960 Hz tone. Front panel start button and light can be removed. **Decoder:** Can use external receiver or optional internal AM receiver; required input 0.3 to 5 volts rms. Piezoelectric tuning fork filters for tone response. Delay time by dividing from received tone. Internal 1-watt audio amplifier and speaker.

Audio Engineering Co., Gary, Ind.	*TE-606/TD-707, Encoder-Decoder	\$295.00
--------------------------------------	------------------------------------	----------

Encoder/decoder assembly sold only as a unit. **Encoder:** Two crystal oscillators, with 12-stage CMOS dividers. Activation closes relay for external signal. 600 ohm output. Panel switch for internal test (feeding tones to decoder). **Decoder:** Encoder tones establish filter band-pass centers, digital circuitry sets bandwidth. Input, 100 mV or more into 10,000 ohm bridging transformer. Tone reception lights panel LED, operates relay for external alarm. LED flashes on peaks during mute to show audio received. Listen mode. Encoder and decoder boards are plug-in; immediate replacements available.

Audio Services Co., Gary, Indiana	EBS-1, Encoder	\$225.00
	EBSD-1, Decoder	125.00
	Integrated Encoder- Decoder, one unit	225.00

Encoder: Crystal oscillators with CMOS digital circuitry. Program loop-through with automatic relay substitution of encoder tones, auto reset to normal after transmission. Three-position switch must be in up position momentarily, along with "Start" button, to activate. Abort is down position. Start and abort controls remoteable. Built-in test mode for internal check, encoder to decoder. Level-set mode for level adjustment during use. **Decoder:** Piezoelectric tuning fork filters for tone detection. Optional plug-in relay for external alarm. Input -20 to +10dBm, high Z, unbalanced. Input audio-fail circuitry, operates panel LED and relay after 10 seconds of audio absence. Listen mode to monitor receiver, set level. Internal loudspeaker.

Avcom, Inc. Columbus, Ohio	EBS-100* Encoder- Decoder	\$249.95
-------------------------------	------------------------------	----------

Integrated encoder/decoder, sold only as a unit. **Encoder:** Crystal oscillators, divided to audio tones. Adjustable timing. Start button and indicator light remoteable. **Decoder:** Band-pass center frequencies set by the crystal oscillators. Input 100 K ohms or 10-ohm speaker load; 1 to 20 v rms input. Remote monitor and reset. Relay for external alarm.

Bald Mountain Lab, Troy, N.Y.	* BML 575E, Encoder	\$229.95
	* BML 575D, Decoder	125.00
	Encoder/Decoder in single package	349.95
	Dual redundant model	575.00

Encoder: Two oscillators, with digital CMOS division. Digital division from 960 Hz tone for transmission timing. Visual indication of tone presence with test button. Isolated from audio line by internal relay, when in stand-by. No series relays, output bridging. Positive abort, remoteable. Separate lamp indicator, test jack, for each tone. **Decoder:** A.G.C. makes input level non-critical.

continued on page 44

McMARTIN

EBS

TWO-TONE EMERGENCY BROADCAST SYSTEMS



EBS-2 Decoder-Two Tone Monitor **\$ 99.50**
FCC CERTIFIED



TG-2/EBS Encoder-Two Tone Generator **\$225.00**
FCC TYPE ACCEPTED

with



AMR-1 AM Fixed Frequency Receiver **\$ 99.50**

or



FMR-1 FM Fixed Frequency Receiver **\$ 99.50**
FCC CERTIFIED

McMartin, a leader in the development of broadcast equipment has available for **IMMEDIATE DELIVERY** the NEW Two Tone Emergency Broadcast System. This system complies with all FCC Regulations. A complete AM or FM system (EBS-2, TG-2/EBS and AMR-1 or FMR-1) will cost you only **\$429.00**.

CALL or WRITE

McMartin Industries, Inc. • 4500 South 76th Street
Omaha, Nebraska 68127 • (402) 331-2000 • Telex 048-485

Circle 135 on Reader Service Card

We've been adding channels to TV systems for 25 years.

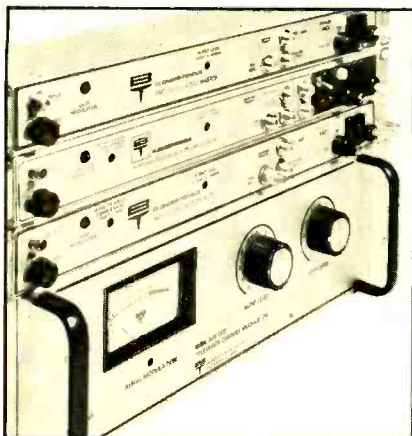

That's why we designed our own modulators.

Our three new modulators incorporate 25 years of experience adding program channels to rf systems in apartments, condominiums, schools, ETV, and CATV systems. We know more about TV system problems than anyone else—adjacent channel, beat problems, any problems involved in mixing into a system.

The AVMT 4923 provides both a modulated visual and modulated aural rf carrier output on any single vhf TV channel.

The VMT 4922 provides a modulated visual rf carrier output on any single vhf TV channel.

The AMT 4921 provides only a modulated aural carrier output and unmodulated visual carrier on any single vhf TV channel.

Rounding out the line is our current AVM 4920, an audio-video model.

- Low video distortion (typically 1.5%) and 90% modulation using 15-kHz video signal.
- High-impedance loop-through or 75 ohm terminating video input.
- Audio distortion (typ. 0.7%) @ 25-kHz dev.
- True peak overmodulation indicators using calibrated light-emitting diodes.
- Vestigial sideband filter response suitable for adjacent-channel color or monochrome operation.
- Independent aural carrier (aural to visual carrier ratio) control.



BLONDER-TONGUE

Blonder-Tongue Laboratories, Inc.,
Old Bridge, New Jersey 08857.

Circle 136 on Reader Service Card

TWO-TONE EBS SYSTEMS

Bramco, Div. of Ledex, Piqua, Ohio *EBS-1226, Encoder-Decoder \$349.00

Combined encoder/decoder. **Encoder:** Uses Bramco RF20 resonant tuning forks for tone generation, one for each frequency. (RF20 is widely used in mobile radio). Automatic reset after 22-second transmit. Output 600 ohms, automatically disconnected when not transmitting. Start and abort panel buttons, can be removed. Closed-circuit mode for internal test (to decoder). Tone test points on front panel. **Decoder:** Each tone detected by RF20 reed filter. Input 10,000 ohms, transformer isolated. Panel indicator and relay for external alarm on tone reception.

Broadcast Engineering Techniques, Providence, R.I. EBS-100, Encoder-Decoder with optional AM rec'r card \$295.00 390.00

Encoder: Temperature-compensated IC square-wave oscillators. Three outputs at 600 ohms each, one always on for checks, two switched on when activated. Start and stop controls can be removed. Switch for internal test, encoder to decoder. **Decoder:** Two CMOS digital comparators, matching signals to generator references. Internal speaker on front panel, with mute control. Minimum input, 0.2 volts at 100% modulation. Listen mode to monitor receiver. NO and NC relay contacts for external alarms.

Elcom Eng. Co. Santa Ana, Calif. *EBG-1, Encoder \$275.00 *EBS-10, Decoder-Rec'r 225.00

Encoder: Two crystal oscillators, division by high-speed monolithic counter for each tone. Front panel start and abort; red LED during transmission, green LED also during first 8 seconds, the abort period. Automatic reset after 22.5 second transmission, or after abort. Closed loop test, encoder to decoder. Program-line loop through available, with relay control. Output 150/600 ohms, transformer balanced or unbalanced. **Decoder/Rec'r:** Phase-locked loop decoders, one for each tone. Two-tone reception activates program loop-through relay, and relay for external alarm. Carrier drop alarm. Decoder can operate with any receiver having minimum output of 30 mV. Receiver is single-conversion superhet with extra circuits for high selectivity; two simultaneous channels, selectable by pushbutton. Signal level indicator; resonant trap at antenna to reduce local transmitter overload. Receiver/decoder usable for present 1 KHz signal, converted to two-tone signal by removing jumpers.

Gorman-Redlich Mfg. Co. Athens, Ohio *CEB, Encoder-Decoder \$195.00 *CE, Encoder only 145.00

Encoder: Crystal oscillator, 3.9 MHz, CMOS digital IC's divide down to audio tones. Front panel start and abort controls, remoteable. Signals available on front panel for test, whether activated or not. Output 600 ohms, transformer. **Decoder:** Filters use encoder tones to set band-pass centers. Looped-through audio line; relay substitutes decoder on receipt of two-tone signal. Relay for external alarm. Minimum input 100 mV; 6 ohms for feed from receiver output transformer; removal of 6-ohm resistor converts to 4700 ohms with .05 mf in series. Uses one power supply, standard IC's plugged into mating sockets, on PC board removeable with four screws. Instruction book shows waveforms at 10 test points.

Harris Corp. (Mfg. by Neff Electronics) Quincy, Ill. *EBS Alert GII, Encoder \$350.00 *EBS Alert DII, Decoder 169.00

Encoder: automatic removal of program audio and substitution of EBS tones, on activation (if desired); audio loop-through, 600 ohms balanced output. Time period adjustable, 20 to 25 seconds. Abort control. Stability, 4 ppm/year. **Decoder:** input, 100 mV to 7.5 V rms, into 200 K balanced or unbalanced. Source impedance, 2 ohms to 20 K, balanced or unbalanced. Time delay adjustable, 5 to 13 secs. Two relays, SPDT, for external alarms, operated on receipt of signal.

International Nuclear Corp. Nashville, Tenn. *NIAC, Encoder \$395.00 TDN2, Decoder, no rec'r 260.00 TDN2, Decoder with AM rec'r 300.00 TDN2, Decoder with FM rec'r 335.00

Encoder: Crystal oscillator. Front panel and remote operation con-

continued on page 46



Introducing a Color Corrector for Electronic News Gathering.

Electronic News Gathering makes tough demands upon the broadcaster. Color imbalance and colorimetry problems are frequently encountered. Matching remote camera shots to indoor studio programs or assembling tapes from different locations or cameras is "chancy" at best. Often that fast-breaking story doesn't allow for camera rebalancing!

Thomson-CSF Laboratories now provides a solution to such difficult encoded signal color problems. With the Model 5500A Color Corrector, you'll be able to rebalance and match video signals *after* encoding. It can be used either after the play-back tape machine or following the microwave receiver during live coverage. In most cases, a noticeably improved color picture will result. For ease of operation, a Remote Control unit is included as standard equipment.

As an added feature, an optional automatic Sensor unit is also available to control the Color Corrector for telecine use.

Whether for Electronic News Gathering, tape production or telecine use, the Thomson-CSF Laboratories Color Corrector System should be working for you. Interested? Give us a call.



THOMSON-CSF LABORATORIES, INC.

37 Brownhouse Road, Stamford, Connecticut 06902

(203) 327-7700 / TWX (710) 474-3346

Circle 137 on Reader Service Card

TWO-TONE EBS SYSTEMS

controls and power lamp. Abort during 8 second delay, remoteable. Front panel test switches and level controls for each tone. Automatic reset after 22.5 second transmission, or after abort. Output 600 ohms, transformer. **Decoder:** Accepts output from any standard receiver, or can be used with INC matching receiver. Input filter, two phase-locked loop decoders. Special compartment to hold INC receiver. Terminals for remote speaker, and for relay to operate external alarm. Internal loudspeaker. Receivers tune the full AM and FM bands, respectively. "Demute" button for listen mode.

McMartin Industries, Omaha, Neb.	*TG-2/EBS, Encoder	\$225.00
	*EBS-2, Decoder	99.50
	FMR-1, FM rec'r	99.50
	AMR-1, AM rec'r	99.50

Encoder: Crystal-controlled oscillator; frequency division by digital IC's. Both manual and auto timing. All control functions can be remote. Can be bridged onto audio line, or fed in as separate source; 600 ohm output. **Decoder:** Tuning-fork decoding filters. Usable with McMartin receivers, or with others having minimum of 100 mV output. Internal loudspeaker, listen mode, relay for external alarm, reset control (remoteable). Two receivers can be connected simultaneously. Circuitry for carrier-failure alarm. **Receivers:** Single channel AM or FM, output 600 ohms, 8 dBm balanced or 1 volt unbalanced. Carrier-off relay.

Monroe Electronics, Lyndonville, N.Y.	Model 920 Decoder	\$298.00
--	--------------------------	-----------------

Decoder: Input, 10 mV to 2 V rms, 20 K ohms. Will operate with noise equal to signal tone in amplitude. Audible alarm plus relay closure.

Rivers Associates, Leominster, Mass.	*DU-Alert 2, Encoder	\$220.00
	*7506, Decoder	
	Complete system, one package	295.00

Encoder: Frequencies crystal controlled. Controls on panel, all remoteable. Automatic reset after timed transmission. Program loop-through, with automatic switching to monitored signals. **Decoder:** Crystal reference for decoding filters. Input, 100 to 200 mV rms. Use-

able with any receiver; optional Rivers AM receiver, crystal controlled. Optional audio amplifier and front-panel loudspeaker. Listen mode; rear plug-in relay for external alarm.

Time and Frequency Technology Santa Clara, Calif.	760 Cabinet (must be used; hold up to three modules)	\$ 40.00
	*760-04 Encoder module	195.00
	*760-03 Decoder module	100.00
	*760-02 FM rec'r module	100.00
	760-01 AM rec'r module	135.00

Cabinet will hold entire system—encoder, decoder, one receiver. Alternately, encoder can be in one cabinet, decoder and receiver in another. **Encoder:** Crystal oscillator for tones. Transmitted digitally timed from oscillator. Two front panel start buttons, must be operated together. Activation automatically removes program audio, substitutes tones, then monitor signals. Start and reset remoteable. **Decoder:** Useable with TFT receivers, or others with at least 100 mV of audio output. Loudspeaker built in. Relay for external alarm when signals received. **AM receiver:** Phase locked loop synthesized local oscillator, tunable by thumb wheel in 10 KHz steps. Carrier-off alarm circuitry. **FM receiver:** Two channels, selectable by pushbutton. Crystals factory installed. Carrier-off alarm circuitry.

Waldon Co., Savannah, Ga.	*EM-100, Encoder-Decoder	\$274.00
--------------------------------------	---------------------------------	-----------------

Integrated system, encoder and decoder in one package. **Encoder:** Crystal oscillator, (3.58 MHz color crystal); CMOS digital IC's for division to audio tones. All controls remoteable. Output 600 ohms, transformer; provision for audio loop-through with automatic switching, if desired, no additional equipment. **Decoder:** Useable with any receiver that has 200 mV to 5 V rms output. LED input level indicator. Front panel volume control; pull switch for listen mode. Test button verifies operation. Reset remoteable. Relay contacts for external alarm. Self-contained speaker and audio amplifier.

At press time: Telco Corp., Knoxville, TN, announced an EBS system. Data too late to include here.

STILL the best buy ... DYN AIR's Series-X Switchers

Forget about messy patch cables and the tedious re-patching to change distribution. DYN AIR's Series-X Switchers provide pushbutton distribution of 6 to 60 color sources to as many as 120 outputs. A high degree of input-to-output isolation allows any input to be switched to any or all outputs without loading the source.

These units are totally modular, allowing off-the-shelf assembly of almost any input-output configuration, either video-only, or audio-follow-video. Expansion is easy too . . . you simply add input or output expansion modules as required.

Wouldn't a Series-X Switcher solve some of your distribution problems?

Write today for full details.

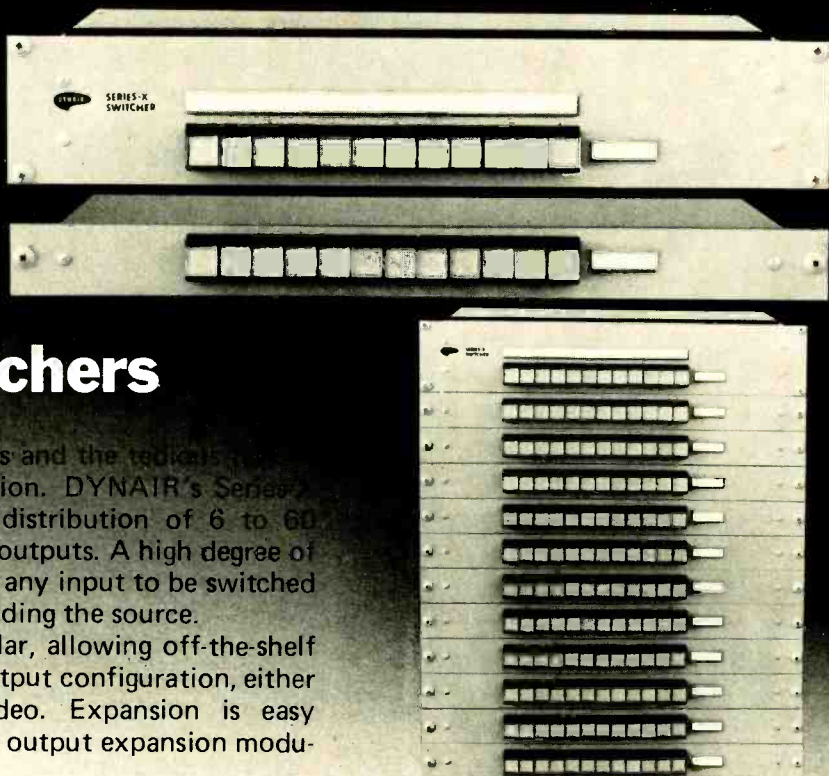

DYN AIR ELECTRONICS, INC.
6380 FEDERAL BLVD, SAN DIEGO, CALIF 92114 U.S.A.
TELEPHONE: 714-582-9211 • TWX: 910-335-2040



Circle 138 on Reader Service Card

The Datatron Newsmaker Is Good News For The Broadcaster



In a world where everything is going up, Datatron is reducing the price of one of its complete electronic editing systems. The system is called the DATATRON NEWS-MAKER. The price is \$23,750. That doesn't buy you a stripped down model. It gets you a sophisticated piece of electronic editing equipment including two Sony 2850 tape decks. It's the perfect editing package for ENG and you can add a Jam-Sync generator to it, if you desire, for another \$3,750.

The Special Newsmaker Package

Datatron's Newsmaker is a complete electronic editing system. The heart of the system is the Model 5050-100 Video Tape Editing Unit. It uses standard SMPTE editing time codes. If you add Jam-Sync this remarkable piece of electronic equipment eliminates the need of pre-recording SMPTE codes on electronically edited master tapes. The system is so simple to operate that non-technical personnel can perform complex editing tasks. There's a simple keyboard entry for all functions and the unit can edit from tape or live video sources. The system displays tape position and all edit points while providing audio, video or audio/video edits.

The **Datatron Newsmaker** package includes two Sony 2850 tape decks and the system is ideally suited to the specialized needs of ENG.

The Deflated Newsmaker Price

\$23,750* buys you the complete **Datatron Newsmaker** package. We weren't kidding when we said it was economical. If you want to add Jam-Sync for

laying down the SMPTE edit code on the entire length of fresh tape during the assemble mode, it brings the total price of the system up to \$27,500. That's still thousands of dollars below competitive systems.

Field Facts About The Datatron Newsmaker

The **Datatron Newsmaker** is an old pro when it comes to ENG. If you've got any questions about how this electronic editing system performs in the field, just ask the news people at such stations as:

WPVI	Philadelphia
KPRC	Houston
WSB	Atlanta
WLAC	Nashville
KNXT	Los Angeles
WTVJ	Miami
WWL	New Orleans
KENS	San Antonio
WTLV	Jacksonville

Or ask the news people at the many other stations across the country that are using the **Datatron Newsmaker**. We'd be happy to give you a long list of references. We'll also be glad to analyze your needs and tell you which Datatron Editing System best meets your needs for today and tomorrow. Write or phone today.

Datatron, Inc., Editing Systems Division, 1562 Reynolds Ave., Santa Ana, CA. 92705 • (714) 540-9330 • TWX 910-595-1589 • Mailing Address: P.O. Box 11427, Santa Ana, CA. 92711 • Eastern Regional Office: 505 White Plains Road, Tarrytown, N.Y. 10591 • (914) 631-4060

datatron, Inc.

EDITING SYSTEMS DIVISION

*Jam-Sync available as an optional extra for \$3,750.00

Circle 139 on Reader Service Card

So Far It's All Go For Electronic News Gathering

ENG efforts to date are nothing but a succession of success stories. With less-than-ideal equipment, stations find they are doing a better job of news reporting than before and at less operating cost. New equipment to hit market in 1976 will make life even easier.

One year ago, we wrote in the January 1975 issue of *BM/E*: "Electronic News Gathering: Its Off The Launching Pad, With Full Flight Ahead." What happened during the year proved that statement, *double measure*.

Last month, for example, we quoted Joseph A. Flaherty, CBS Television Network, predicting that by the end of 1975 132 independent television stations would be equipped with ENG systems, reaching, collectively, 65% of all television households in the U.S. And we have just seen the results of a private survey indicating an even higher usage. Out of 780 stations reporting, one out of four already has ENG equipment. Moreover, judging from the camera sales the leading makers are reporting, *BM/E* concludes that the proportion may be higher still.

But despite the remarkable distance ENG has moved to date, we can safely say, "You ain't seen nuttin' yet!"

The first CBS ENG scoop was just over four years ago and we are already seeing the third generation of cameras emerge—cameras lower in weight and lower in power drain. The very latest is the 11 lb. Thomson CSF Microcam announced just this month.

ENG has been launched successfully using borrowed videotape recorders. The principal recorder in use today is the Sony VO 2850 cassette recorder/player system coupled with the Sony 3800 portable recorder units. Those who don't try to match 16mm film quality use the less expensive Akai 150 system. Both the Sony and Akai products were designed for industrial-educational use. In 1976 we will see Sony introduce a cassette recording system designed specifically for the broadcaster. This equipment will be unveiled at the NAB convention in Chicago March 21-24. Other new alternative recorders offered to broadcasters will be portable segmented-helical machines from Echo Science and Bosch-Fernseh.

ENG got launched without a clear-cut answer to the editing problem. The early Sony RM 400 designed to work with 2850s is a little too simple; the popular Datatron 5050 Vidicue SMPTE system is described by some as an overkill system. But editing devices for ENG are now evolving at a feverish pace with new companies and new systems appearing on the scene regularly. For example, since the last NAB convention, CMX has introduced the System 40 for ENG and first deliveries have begun. Television Research International announced an interface for the VO 2850 using its Moviola-like system, the TR-5. Convergence Corp. converged on the industry mid-year with a joy-stick operated frame-by-frame editor for the 2850. Spectravision has showed a similar editor, though the company is not marketing specifically to the

broadcast industry. We expect other companies to demonstrate that they are in this market by NAB time. Although Sony isn't saying, it's realistic to expect them to come out with a new editor as part of their complement of new equipment to be shown at NAB.

Thus in three ENG areas, the state of equipment development is fluid but the current is swift. ENG is a concept whose time has come, but it has a long way to go.

The availability of today's mini equipment regardless of shortcomings is tremendously significant, however, and is having an impact on other departments at broadcast stations. A quarter to a third of the stations doing ENG are also into commercial production and documentaries using mini equipment. The value of mini equipment in doing fast local commercials is self-evident. But such use also makes the decision on what equipment to select more difficult. Achieving video news as-good-as-16mm film news is one thing; it does not follow that the news equipment is adequate for commercial production. If special effects are desired, or if a great deal of editing is necessary, one gets into third and fourth generation tapes. A lot of today's ENG equipment is not adequate for these more demanding applications.

What follows in this report is some of the knowledge learned about electronic news gathering this last year. We include both some detailed case histories and some summarized advice from the experts. But before doing so we should review what is happening in equipment. Some of the case histories that follow were deliberately chosen to describe some of the newer equipment in operation.

Cameras: As we head into 1976 the camera in most widespread use is the Ikegami HL33. Close to 200 such cameras are in the field. At NAB, 1975, Ikegami announced the more sensitive HL35. Now about 100 of these units are in the field. The company reports a backlog of 100 orders for the HL35. That's a lot of cameras.

Despite the heavy sales of the HL35s, the camera most discussed this last year was the RCA TK-76. Shown in prototype form at NAB '75, the TK-76 was an instant winner. RCA has announced sales of over 100. Deliveries, however, have not begun and won't until April of 1976.

The TK-76 has gone through one styling change since its introduction, see photos. In both the original and late form, it represents a significant weight advantage over the Ikegami. For that reason, it can be labeled a third generation ENG camera, the first being the Philips PCP-90 and the second being the HL33/HL35 series and its equivalents.

A characteristic of the RCA camera as a third generation camera is the elimination of a backpack as such. Electronics are all in the head. A second package is the power pack or battery pack. Altogether, including camera, lens, viewfinder and power pack, the weight of the TK-76 is under 25 lbs. A padded shoulder support adds about 3.5 lbs., however. By contrast, the HL35, with its larger backpack unit, weighs over 40 lbs. Both cameras use 3/8-in. Plumbicons.

The race for smaller cameras of high quality is on. A new contender with no backpack is the Toshiba CK-38. Unveiled at the 117th SMPTE convention in Los

Angeles in October and shown on page 6 of BM/E last month, this compact camera with head, lens and viewfinder weighs under 15 lbs. The CK-38 uses three 3/8-in. Chalnicons. Under normal operation, objects can be picked up at 40 to 50 ft. candles of light. By increasing the sensitivity 6 dB, pick up is possible in 20 to 30 ft. candles. The camera is expected to sell in the U.S. for about \$12,000 (sans accessories). Broadcasters who've seen it are impressed by its performance and price!

U.S. broadcasters attending the NHK-sponsored International Broadcasting Symposium in Tokyo in late October 1975 report other backpackless cameras.

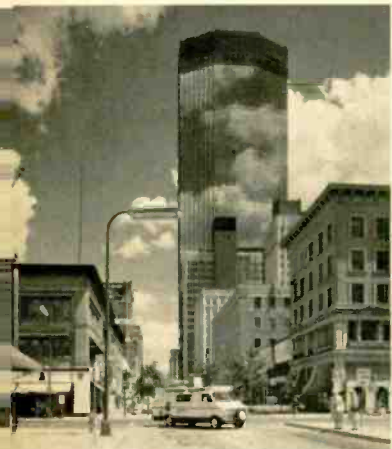

KSTP-TV, St. Paul, shoots about ten stories live a week from the scene of the action and eight or nine are put on tape. Ron Magers, News Director, predicts that tape will eventually

replace film. Photos above show KSTP-TV van on streets of Minneapolis, out at the airport, and at one of the Twin Cities many parks.



KSTP-TV uses mini-TV equipment for commercials, promotions and documentaries. Scenes here show Karen Grassle, star of "Little House on the Prairie," standing on the banks of Plum Creek, original site of the House on the Prairie.



Mini-TV ENG cameras are great for sports, too. Here Editel's ENC-II broadcasts a tennis match for CBC.

Thirty foot mast on KSD-TV's ENG van is featured in this group shot of part of KSD's news crew. Note that film cameramen are still part of the regular crew.

ALL GO FOR ENG

Nippon Electric Corp. has a MNC-1 model weighing less than 14 lbs. Shibaden (Hitachi) is reported to have shown an SK-80 model which is a one-piece unit. It is oriented more towards ENG than is the SK-70.

Despite these remarkable weights, none has the edge on the Thomson-CSF Microcam announced this month. The Microcam, a product of a joint development effort between the CBS Television Network and Thomson-CSF (successor to CBS Labs), weighs only 11 lbs. Furthermore, it consumes only 22 watts of power.

The Microcam, trademarked, incidentally, is a two-piece unit—camera head and electronics pack—but the latter weighs only 3 lbs. and can hang on a belt. The Microcam two-piece arrangement seems to be a neat solution. Each of the elements can be operated and carried independent of each other or they can be combined. The 8 lb. camera head can be handled with one hand/arm just as is the conventional film camera. Joseph Flaherty of CBS Television Network points out there is no need to put everything in one package. Film cameras are one-piece because they have to be.

Miniaturization has reduced power consumption of the camera components to remarkably low values: camera head, 8.5 watts; viewfinder, 1.5 watts; electronic pack, 12.0 watts for a total of 22 watts. These low power requirements permit extended operation of up to one hour with a NiCd battery pack rechargeable in three hours as standard. A 15 minute recharge is available as an option. Batteries are ten ½ D cells and weigh 2.5 lbs.

per conservative hour of operation. Among the camera features are these: full two/line image enhancer with comb filter, level dependence and crispness; full three-channel masking amplifier (matches studio camera colorimetry); encoder with full I & Q including phase compensation and switchable color bars; sync. gen. meeting FCC and network specs; color gen lock by means of external video or black burst; auto iris, master black and white; warm up, four seconds from standby; F 1.4 prism assembly. The standard lens is a Canon 6/1 F 1.5 with Fuji A 7×11 or Canon 10/1 F 1.8 available as extra cost options.

The price of the Microcam will be under \$30,000. An operating unit will be demonstrated at NAB in March with initial production units scheduled for delivery in Summer 1976.

While top attention getting cameras are low in weight and power drain, others are headed in the direction of high quality and versatility first and compactness second. Thus the claim of one of the newest cameras to hit the scene, the Ampex BCC 2, is that it doubles as a production camera. The BCC-2 uses 1-in. Plumbicons and is in a league with higher quality units available from Editel, Fernseh, IVC, and Marconi to name a few.

The Ampex BCC-2 was exhibited at the NAEB show in November in conjunction with another new compact studio camera from Ampex, the BCC-3. These two units can work together through an interface backpack to make up a formidable production system. This combination is highly prized in Europe where the emphasis is more on documentaries or specials than news. Thus Ampex looks

continued on page 52

ABCDEFGHIJKLMNOPQRSTUVWXYZ
1234567890\$#&?[]<>*+;:!.^



Broadcast Clarity • Built-in Monitor • 8-page Memory

The TCG-1432A Character Generator,
Including Monitor and Memory Options...

TeleMation's excellent character generator — the TCG-1432A — including its optional monitor and 8-page memory, is now available for less than \$3,200. Here is a titler of proven performance and standard design features meeting broadcast criteria:

- A built-in matting amplifier.
- A 120-element character matrix, with shadow edging, for exceptional clarity.
- 16 lines of 32 characters (14 lines within SMPTE Safe Title Area).
- A built-in RS-170 sync generator with genlock.

Versatility is assured for the TCG-1432A by its many plug-in accessories and optional add-ons. Among these, its color background generator with custom-designed patterns, digital clock and audio-tape memory coupler are now also offered at new, low prices.

Call us for details.
(801) 487-5399



TeleMation
the discovery people

P. O. BOX 15068, SALT LAKE CITY, UTAH 84115

ATLANTA • BOSTON • CHICAGO • DALLAS • DENVER • LOS ANGELES
NEW YORK • OMAHA • SAN FRANCISCO • WASHINGTON, D.C.
BEIRUT, LEBANON • LONDON, ENGLAND • MEXICO CITY, MEXICO
RIO DE JANEIRO, BRASIL • SANTIAGO, CHILE

...for
less than
\$3,200

Circle 140 on Reader Service Card

Watts your problem?

Harris offers the world's most complete line of FM broadcast transmitters. From 10 to 40,000 watts. All with a TE-3 100% solid-state exciter employing DCFM (direct carrier frequency modulation) and

DAFC (digital automatic frequency control).

All transmitters have an INTERMODULATION specification of 0.5% mono and 0.5% stereo. EFFICIENCY — the 20 and 40 kW transmitters

have a final amplifier efficiency of 80%. All are available for prompt shipment.

Write Harris Corporation, Broadcast Products Division, Quincy, Illinois 62301.

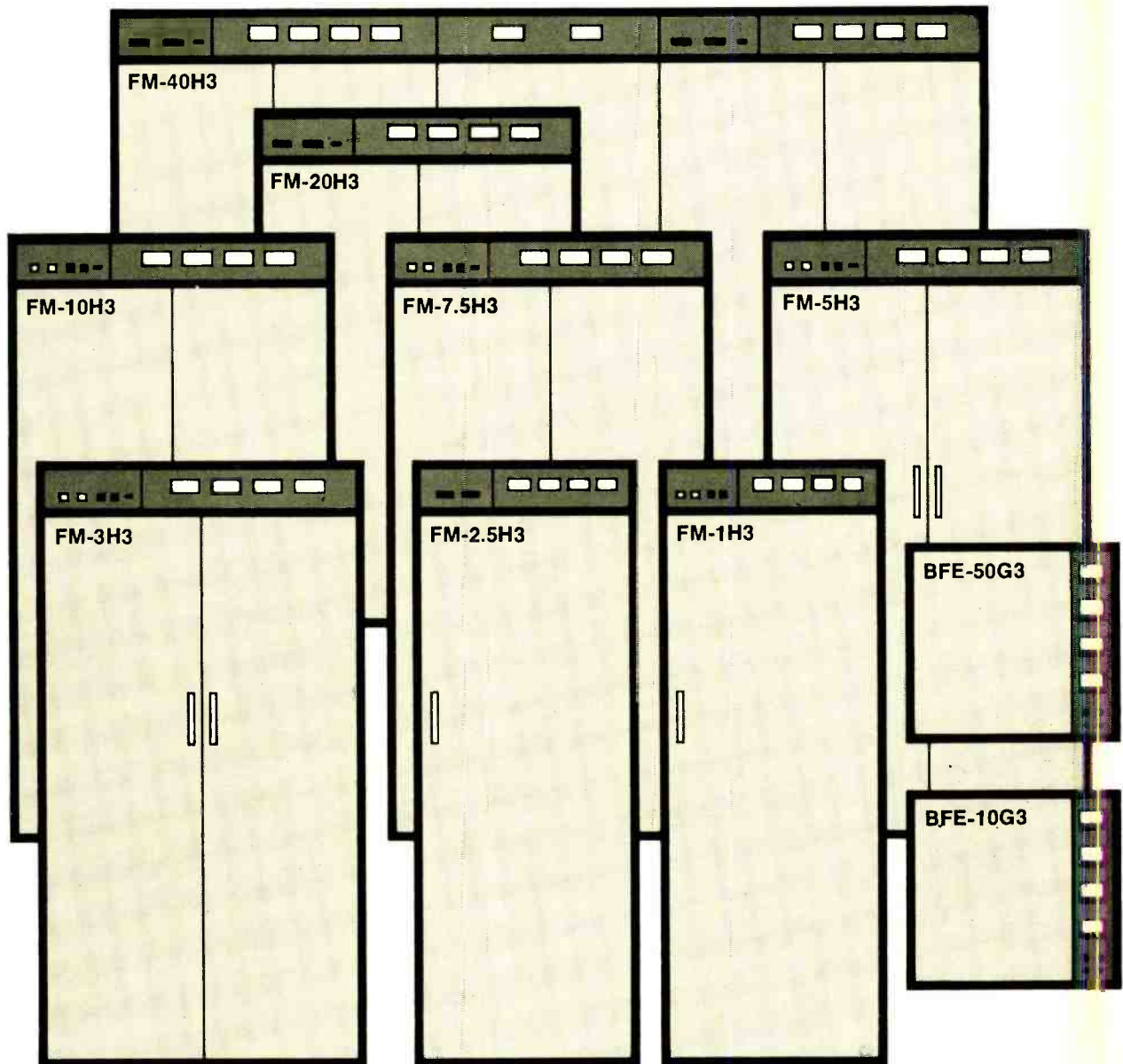

HARRIS
COMMUNICATIONS AND
INFORMATION HANDLING

Circle 141 on Reader Service Card

ALL GO FOR ENG

Latest ENG entry is the Microcam from Thomson-CSF. Head, lens, and viewfinder weighs 8 lbs.; electronic pack and batteries 3 lbs.



RCA's TK-76 is a one piece unit. Virtues of a tiltable viewfinder are obvious.

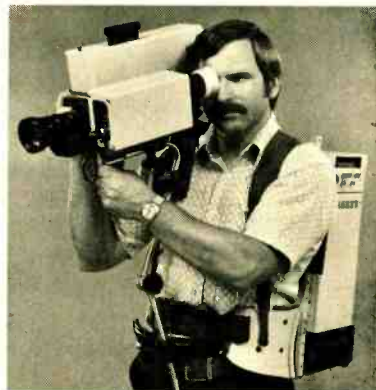

Ampex's BCC-2, using a backpack, features 1-in. Plumbicons. Unit interfaces with BCC-3 studio camera.

not only at the ENG market but also at the emerging field production market. "You don't tie up your resources in a single application camera," says Charles Steinberg, Ampex VP. (Incidentally, the first delivery of the no compromise IVC 7000P portable camera will be to England—Thames Television for use in producing the Week-end News program.)

The BCC-2 measures 13-in. long × 4-in. wide × 8-in. high. The camera head weighs 15 lbs. and comes with a shoulder support, 19-lb. backpack and harness. A rugged, cast aluminum case provides easy and safe assembly, disassembly and transport of the camera for use on location. The battery pack provides 1.5 hours of operation. The portable camera comes with a 10× zoom lens and tiltable mount.

There have, of course, been interesting developments on the other end of the camera scale. The Sony DXC 1600 with its Trinitron tube has sold well. It has possibly overtaken the two-tube Akai VTS 150 in the market place (stations for each being near the one-hundred mark). A very interesting one-piece camera just announced is the new one-tube camera from Hitachi, the FP 3030. Its new tri-electrode vidicon provides good color uniformity and stability. Its weight at 7.7 lbs., total, comes in under that of Sony at 20 lbs. (with CCU), Akai at 13 lbs. (with CCU 150) and the JVC 4800 at 11 lbs. (with adapter). The company does not consider the camera to be suited for ENG, however, and is not prom-

oting it as such.

In the discussion so far we have not mentioned Asaca or Philips. A few Asaca 3000s are being used and one interesting application will be noted later. A Philips unit, the LDK 11 using an Asaca camera modified for Plumbicon tubes, was shown at NAB last year. It has not been heard from since but we can presume that both companies will be in there pitching at NAB '76. The way things have been developing, we won't be surprised to see other contenders at NAB Convention time this year.

Videotape Recorders: As mentioned earlier, the biggest news in the area of videotape recorders is that Sony will be unveiling a broadcast version of the VO 2850 and the 3800 cassette systems at NAB '76. Sony didn't want to release any details at this time but experienced broadcasters expect a unit with a few more meters, separate luminance and chroma controls, standard connectors and perhaps a unit with a plug-in time base corrector. Broadcasters can play the 2850 directly on the air if they can cue it up precisely. Perhaps Sony will make this easier to do.

Interestingly, a near carbon copy of the Sony equipment bearing TEAC's nameplate seen at NAB '75 has not materialized. Unofficial word is that Sony did not want the competition. There is talk that JVC will come up with a unit that will do everything the 2850 will do but better. JVC is expected to make an announcement in January.*

There is no expectation that portable quad recorders will become viable for ENG. Units by RCA, Ampex, and Asaca are too heavy and draw too much power. Such units, however, are finding a niche in mobile vans designed for production work. KSTP-TV, St. Paul, for example, finds the RCA TPR-10 invaluable for outside broadcasting including commercial production.

Of greater interest than portable quads will be the portable helical segmented scan units announced by Echo Sciences (Arvin Industries) and Bosch-Fernseh. These units feature full broadcast station quality. Both are using the two-head transport system developed by Arvin/Echo and widely used in military-space airborne recorders. At the present, the two companies have not agreed on a standard format.

The systems of these two companies have been developed with European Broadcast Union requirements in mind. Quadruplex recording performance is exceeded. A backpack record-only model is part of each system so there are ENG/field production implications. The Arvin/Echo backpack weighs 38 lbs. including the battery. This unit will record for 30 minutes using 8-in. reels of tape. The Bosch/Fernseh BCN unit weighs 48.5 lbs. but allows 52 minutes of recording time.

As part of the overall Arvin/Echo system, a very super high band color electronics system is used. A pilot signal makes it possible to interchange tapes with good stability. The system uses a single motor for both the tape transport and the head scanner. Full servo control and dual capstan drive is featured.

The BCN 20 is equipped with an automatic assembly system permitting on-air tapes to be produced im-

*Late information indicates a capstan-servo unit the CR 8300 U and a portable CR4400U will be introduced at the NAVA convention in New Orleans Jan. 12 and at the SPMT Winter meeting in Detroit Jan. 23. Feature of the 8300 will be a backspacer; portable unit has low power drain.

mediately by assembling the recorded tapes. Price of the portable unit is in the \$30,000 range. A complete studio recorder player is in the \$57,000 range.

Videotape Editors: Editing systems in heaviest use today are the Sony RM-400 system and the Datatron 5050. The TRI EA-5 with Sony VO-2850 interface was announced in July of 1975 and is now quickly finding its way into stations. How it is used at KSLA-TV is detailed later. It was taken by ABC to Peking to cover President Ford's recent trip to China.

The CMX-40 announced in June is in use at WSM-TV, Nashville, KSD-TV, St. Louis, and is slated for more widespread use. Convergence Corp.'s ESC-1 editor control system made its debut in mid-summer. It was used by the CBS Network (on a loan basis) to cover President Ford's recent China trip. First production units have been sold to stations WITI-TV, Milwaukee, and KOOL-TV, Phoenix.

The basic limitation of the inexpensive (\$1,000 price range) but simple Sony RM-400 system has been the fact that one could not move the tape backwards. You had to rewind and try again. Accuracy to within a few frames is possible (depending on operator skill) but this means the desired video frame or audio cue could be missed. NBC has been able to modify the Sony system to advance backward and forward and it is likely that the new Sony line will include an improved editor.

By spending \$5,000 instead of \$1,000, frame accurate editing is possible (subject to tape stretch or other factors that would render the pulse counting system inaccurate). The concept back of these editors is the "Moviola" type manipulation used in film editing. When reel-to-reel recorders are used reels can be manually rocked back and forth. TRI, who pioneered this editing concept, adapted its EA-5 system to most major manufacturers of the helical reel-to-reel machines: Ampex, Akai, IVC, Sony. It has been harder to accommodate the cassette 2850. TRI solved this by coming up with an auxiliary control panel which becomes an extension of the editing consoles push buttons.

An operator has at his fingertips all the normal editing controls plus those controls unique to the VO-2850 including a selection of 4 speeds in forward or reverse, insert or assemble edit mode selection, end insert push button, monitor display switchable between the two VTR's, and edit cue selection from either video or audio cues (automatic compensation for the 1/2 second audio delay in the format). The operator also has at his fingertips the normal remote function controls of the VO-2850 ie.; Stop, F. Forward, Rewind, Forward, and Pause.

The result gives an editor total control over his VTRs through a series of push buttons. The 2850s need not in fact be located in the immediate area where the editing session is taking place.

The Convergence Corp.'s ESC-1 system substitutes a joy stick control for speed pushbutton control found in TRI's auxiliary control panel.

When the operator moves the joystick slightly to the left, the tape will crawl backward, with the frame bar just inching up the monitor screen. With a slight movement of the joystick to the right, the tape will crawl forward. The farther over in either direction the joystick is moved, the faster the tape will move—up to three times normal speed for rapid scanning of program mate-

continued on page 54

WORLD'S BEST STEREO GENERATOR

WILKINSON ELECTRONICS SG1E

POSITIVE PROOF

- * 60 db separation 50 Hz-7500 Hz
- * 55 db separation 7500 Hz-10000 Hz
- * 50 db separation 10 KHz 15 KHz
- * FM Noise - 75 db Cross Talk - 60 db



- COMES COMPLETE WITH POWER SUPPLY
- REQUIRES ONLY 3 1/2" RACK SPACE
- ONLY ONE FRONT PANEL ADJUSTMENT
- REMOTE STEREO ON/OFF FUNCTION

WORLD'S BEST FM EXCITER

WILKINSON ELECTRONICS FME10

POSITIVE PROOF

- * Frequency response $\pm 1/4$ DB 15 HZ-350 KHz.
- * FM Noise Level - 70 DB below 100% Mod.
- * Distortion - 0.3%
- * Modulation - Direct FM
- * Power Output - Adjustable to 18 watts
- * Stability 1 part in 100000
- * Requires no oven and is not susceptible to rumbles and microphonics



- FCC TYPE ACCEPTED
- POWER SUPPLY INCLUDED
- REQUIRES 7" VERT. SPACE
- IMMEDIATELY USABLE IN ANY TRANSMITTER
- SHIELDED BY BOTH STEEL & ALUMINUM
- COMPLETELY METERED
- ADJUSTMENT FREE

NO ONE CAN MATCH THIS COMBINATION

WILKINSON

ELECTRONICS, INC.

701 Chestnut St.
Trainer (Chester) PA. 19013
Telephone (215) 497-5100

Circle 142 on Reader Service Card

ALL GO FOR ENG

rial. By moving the joystick back and forth, it is possible to rock the tape reels back and forth to select a precise audio cue.

The next jump in editing equipment is to go to SMPTE time code editors—those made by Datatron starting at \$13,000, or CMX starting at \$20,500. These units offer absolute frame accuracy. The Datatron system uses a hardwired logic control and digital display readouts. The CMX used a standard computer and a CRT display. The Datatron 5050-300 system can use a Nova computer as an option.

There are many who feel the time code editor approach is unnecessary for news. On the other hand, these systems do make great sense when there is a union jurisdictional problem. If final editing equipment must be run by technicians, who can not make creative decisions, then giving them an edit list in SMPTE time code is a good answer.

Some stations justify their purchase of the more costly CMX-40 or Datatron systems this way: "We can always use this equipment in production if we decide we can use less expensive editors for ENG."

Our discussion assumes off-line editing by news people is normal. At some stations on-line editing is done using Central Dynamic's SMPTE time code EDS-200 editor.

Those who have not yet bought other than the simplest editors are comparing systems carefully, analyzing the time it takes to do edits. This means some hands-on

experience is valuable. If one wants to do A-B rolls, three VCR systems are necessary. This means CMX or Datatron systems are desirable.

The whole process of editing is one phase which has received the least attention by broadcasters. But many companies are now giving a lot of thought to the equipment and the approach necessary. TRI just recently announced the SUN system which puts a number visually on each frame without using audio or cue tracks. You can see the number in a still frame mode while working with helical VTRs. This system was developed for production work, but it is indicative that some new ideas are coming.

Other Equipment Advances: Since we are already into fourth generation time base correctors (counting analog time base correctors integrally designed into quad recorders) there is not much new since BM/E's report of last January. Consolidated Video Systems has announced a new CVS 504B digital time base corrector. It has been designed to compensate for gyroscopic effects on videotape recorders which occur if the machine is moved or turned while recording.

In the microwave area, the biggest development is that companies other than Microwave Associates and Nurad* are emerging. Micro Communications is now a competitor to Nurad for polarized antennas and Farinon and Terracom are using the word ENG in their product descriptions. Other names are likely to become associated with microwave for ENG in the near future.

*At press time Nurad announced a 7 GHz Model 70 QPI quad polarized system giving broadcasters an option of either 2 GHz or 7 GHz operating band.

continued on page 56

Need Only Three DA's? Introducing the RF-175 Rack Frame and Power Supply:

Now you can install any module shown here in a 1-3/4-inch rack frame — the TeleMation RF-175. This new rack frame, which includes a built-in power supply, is ideal for use in remote vans, small studios, or any location where a limited amount of terminal equipment is required. Select any combination* of modules from four Pulse DA's, five Video DA's, two Subcarrier DA's, Sync Generators, Sync Changeovers, Genlock, Bar Dot Generator, Dual Source Identifier — whatever your needs dictate.

*Due to power requirements, only one TCG-4 can be installed in an RF-175.

RF-175 Rack Frame and Power Supply



TeleMation
the discovery people

P.O. BOX 15068, SALT LAKE CITY, UTAH 84115 (801) 487-5399

Circle 143 on Reader Service Card

Old-New Reel Time Recorder

Telex/Magnecord series 1400 broadcast quality recorder/reproducer. An old name that spells reliability. A new design for today's state of the art.

- The Old. Telex/Magnecord products are still made in the USA so parts and service are always available. The series 1400 is still built on a solid die cast aluminum main frame for reliable operation around the clock. It's still available in full, half and

quarter track configurations, has fail safe differential brakes and accepts 8 1/4 inch reels. It also still comes with three motors—but then, that's touching on the new.

- The New. A brushless d.c. servo drive with a crystal oscillator control reference so accurate it virtually eliminates program timing errors. New, three speeds: 3 3/4 - 7 1/2 - 15 ips. New catenary head block for straight tape loading, the convenience of one hand cueing and the bi-level illumination of push button controls. New DTL logic controls eliminate EMI and provide fast, spill

proof tape handling gentle enough for half mil tape. And new electronics, clean to 60 dB S/N at all speeds.

- If you're looking for a real time reel recorder with old name reliability but designed for today's demands, you'll find it in the Telex/Magnecord series 1400. For complete information please write:



PRODUCTS OF SOUND RESEARCH

TELEX

COMMUNICATIONS, INC.

9600 ALDRICH AVE. SO. • MINNEAPOLIS, MINN. 55420 U.S.A.

Europe: 22, rue de la Legion-d'Honneur, 33200 St. Denis, France

Canada: Telak Electronics, Ltd., Scarborough, Ontario

Circle 144 on Reader Service Card

ALL GO FOR ENG

Lessons from St. Louis

One of the principal proving grounds for ENG is St. Louis. It's at KMOX-TV, St. Louis, that CBS elected to go all-electronic news, the first top-market station to abandon film entirely. And even before KMOX-TV made its dramatic switch, KSD-TV, the NBC affiliate, was already into electronic journalism using the extremely portable Akai equipment.

The physical set-up at KMOX-TV has remained unchanged this last year but the news *has* changed. Former general manager Tom Batista, now VP, station services, for corporate CBS, says KMOX-TV aired 22 to 27 percent more stories with ENG than before. Three van-equipped crews can go on the air via microwave. A fourth crew is about to be added, but the latter will use a sedan and will not have microwave. The street recorder is the Sony 3800; IVCs are in the van for backup and stories microwaved to the studio are recorded on IVC helicals for editing.

The Electronic News Coordinator organizational structure, as described last year, is intact, and is the model for future CBS O&O stations switching to all-electronic news. (Chicago by mid-76; Los Angeles in '77. Philadelphia is partly there now and does week-end news with ENG equipment exclusively. New York will be last to switch because of microwave problems.)

The quality of picture produced by KMOX has caused rival KSD-TV to upgrade from Akai gear to Ikegami HL-33 and HL-35 cameras. KSD-TV is also using

Record/playback station at WSM-TV shows one Sony 2850 (another will soon be added), two CVS 504 time base correctors and a NEC frame synchronizer.



Editing facility at WSM-TV features a three-VCR CMX-40 system.



microwave. Chief engineer Ed Risk says KSD-TV has a \$120,000 van in regular operation now and a second is being readied. Major feature of the van is a 30-ft. mast for the antenna dish that helps operators establish a reliable microwave path just a little faster. Risk says sometimes a van has to move only a few feet to get a signal

continued on page 70

WHO SAYS A QUALITY ROUTING SWITCHER HAS TO BE EXPENSIVE?

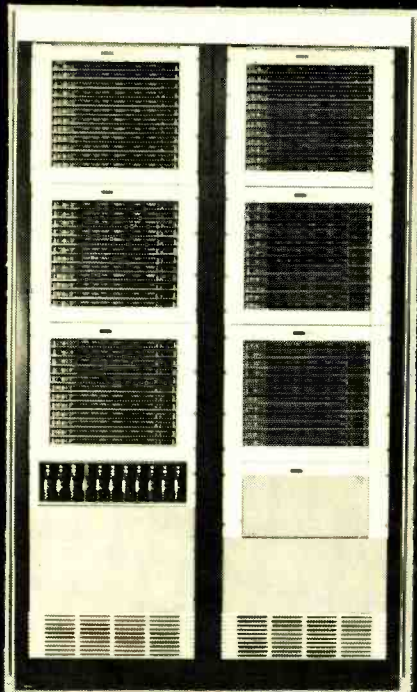

12x74 VIDEO/AUDIO SWITCHING SYSTEM

HOW ABOUT A COMTEC 15X VIDEO/AUDIO SWITCHER AS LOW AS \$47 PER XPT (REMOTE) OR \$31 (LOCAL)

FEATURES

- ★ MODULAR SYSTEM — Plug-in boards for ease of maintenance
- ★ CHOICE of push-button, TWS or X/Y control
- ★ LOW CROSSTALK — typical 55 to 60 dB below 1 Volt
- ★ FOUR REGULATED P.S.'s
- ★ REMOTE OR LOCAL CONTROL (or mixed)
- ★ CHOICE of 8, 12, or 15 inputs per frame
- ★ BALANCED AUDIO IN & OUT — all solid state
- ★ QUALITY STATE OF THE ART COMPONENTS

Ideal for VTR inputs, house monitoring, network, instruction carrels, etc.

Send your requirements to ComTec, your Switching Specialist — over 25 years of experience.

COMTEC

**COMMUNICATIONS TECHNOLOGY, INC.
3070 LEEMAN FERRY ROAD
HUNTSVILLE, ALABAMA 35801
205-883-7370**

Circle 145 on Reader Service Card



CHOICE, TO MAKE YOU HAPPY. SERVICE, TO KEEP YOU THAT WAY.

At Canon, we offer the widest, most customized range of optical products for the broadcast field... to meet your requirements in terms of function *and budget*. From the lightest-weight, most compact, most popular ENG lens on the market (our 12-120mm PV10x12) to an enormously-versatile 32-1070mm with *continuous* zoom (PV34x32BDZ) that gives you the widest choice of focal length/relative aperture combinations.

But beyond flexibility and value, Canon offers you something more. The technical support of a nationwide service organization that's factory-trained and fully equipped. Plus the added security of a comprehensive loaner program, to keep you in action no matter what.

Whatever your requirements, talk to us. You may be in for some happy surprises.

Canon[®]

Canon U.S.A. Inc.

Head Office: 10 Nevada Drive, Lake Success, N.Y. 11040 • 140 Industrial Drive, Elmhurst, Ill. 60126 • 123 Paularino Avenue East, Costa Mesa, Ca. 92626

Canon Optics & Business Machines Canada, Ltd. 3245 American Drive, Mississauga, Ontario L4V 1B8, Can.

Canon Amsterdam N.V. Industrial Products Division, De Boelelaan 8, Amsterdam, Netherlands

© 1975, Canon U.S.A. Inc.

Circle 146 on Reader Service Card

Total Changeover To ENG Improves "Product," Raises Efficiency, Saves Money At WOR-TV

by Richard Quodomine

The Minicam has allowed a return to the two-man news crew of the pre-film era. In this article a big-city Chief Engineer tells how to get the maximum in cost saving, efficiency, and news creativity from a total ENG operation.

Electronic news gathering (ENG) may seem revolutionary to many in the TV industry, but to a 35-year veteran of radio and TV like myself, it simply means that we have come full circle. Radio news teams in the field in the early days consisted of two men, as they do for ENG—a reporter and an engineer. But by the early 1960's TV newsmen had become moving men, carting large studio cameras all over the city. Facility arrangements became increasingly complex—what with telephone lines to connect, power sources to plug into, parking permits to obtain, and similar ramifications.

In the 1960's however, the small TV film cameras came into use, and for the next five to fifteen years a non-electronic element—photographic film—emerged as the key part of TV news-gathering operations. Now, with ENG becoming more and more widely accepted for use, we are returning to the earlier days, with a much more convenient operation—and with the two-man team of radio back on the job.

WOR-TV entered the ENG era in December 1974 with the acquisition of three Akai VTS-150 camera systems. We were the first VHF in New York City to make a bold and dramatic one-step conversion to full ENG. I selected the Akai VTS-150 primarily because of its low cost (about \$7,000 per system) and its light weight (only about 22 pounds). However, it also provides our staff with unique ease of operation and editing capabilities, and few maintenance problems.

Cost saving is real with ENG

Our experience with ENG since last December has proven extremely favorable and has more than met all expectations. This has been particularly true in the area of cost reduction, where the conversion from film to tape will probably save us an estimated \$50,000 to \$65,000 a year.

When you are discussing a single-use medium such as film with a price tag of about \$35 for a 10-minute reel, plus an hour in the film processor with its labor and chemical costs, you have a high-cost element in your budget. At WOR-TV, we were using about \$65,000 a year in raw stock for news film alone. Since obtaining the Akai units, our newsgathering medium is a 26-minute reel of quarter-inch video tape at a cost of about

\$9. As a result of the changeover from film to tape, our high film costs have been reduced to a tape outlay of about \$3,000 a year. Furthermore, tape is normally reusable for anywhere from 10 to 50 times. Consequently, our savings on film alone will have paid for all three Minicam systems plus the time-base corrector equipment in less than a year.

The potential savings in labor costs are equally dramatic. As already noted, it is now possible to have a two-man team—the reporter and the engineer. Our experience at WOR-TV indicates that ENG needs a "universal" engineer for every phase of the non-reportorial operation. He (or she) can handle the camera, bring the tape in from the field, and, working with the reporter and news director, can even edit the story onto the final two-inch video tape. In this way no transfer of information is required, and there is no possibility of communication problems arising. One man—the engineer—can carry the assignment through from beginning to end.

More flexible, more creative use of engineers

Previously, WOR-TV was required to send out a three-man crew, plus the reporter. The crew consisted of a cameraman, a lighting man, and a sound man. From an assignment viewpoint, the new system makes manpower scheduling of union trades much easier and allows for greater flexibility. Instead of five union classifications (cameraman, lighting and sound man, film processor, film editor, and engineer), we now have the engineer alone as our ENG technical-artistic man.

The engineer, however, is not just a technician. His knowledge of every phase of creating the end-product makes him something of a creative artist as well. Furthermore, the engineer does not require special training in the operation of the minicamera—only familiarity with the ENG equipment.

A great deal of careful thought was given to all aspects of ENG before WOR-TV entered into this new medium. We selected our engineers to handle this assignment after evaluating their efficiencies, skills and abilities and considering any economies that might be effected. We also carefully examined the terms of our union contracts.

Through our study, we found that the expertise of our engineers qualified them to handle fast-breaking news better than non-engineers would. All of them had previously handled pre-scheduled news events with large studio-type cameras and most had experience with

Mr. Quodomine is Chief Engineer, WOR-TV, New York City.



Carol Hall covers the Federal Court House in New York for WOR-TV. The Akai color camera recording the scene is being handled by engineer Bob Hennessey.

WOR-TV sportscaster, Ralph Kiner, recently inducted into baseball Hall of Fame, interviews a fan before start of Mets game at Shea Stadium, as engineer Steve Aronson videotapes the event.



Ron Gerrilini (left) and Bob Hennessey transfer quarter-inch VTR to two-inch master tape for final editing before it is put on the air.



Reporter Duke Wade working with engineers Clarke Baker (left) and Ralph Aluise, in editing a story he had recorded earlier that morning.



Joe Kasper, Maintenance Supervisor, and engineer Earl Neely, setting up an Akai camera and videotape recorder. Units are checked carefully every morning before they are taken out on assignment.



Richard Quodmine, Chief Engineer at WOR-TV in New York, puts the finishing touches on the alignment of one of the three video cameras.

baseball, football, and other sporting events, as well as with dramatic shows and telethons. Their knowledge of electronics also would enable them to make proper adjustments and repairs in the field, thereby saving stories that might otherwise be lost if a malfunction of equipment should occur.

Union hangup: a ruling cleared the way

I don't want to leave the impression that we had no

labor problems in effecting this change. All our technical employees are members of the International Alliance of Theatrical, Stage Employees and Moving Machine Operators—IATSE. When the Minicam operation was assigned to the engineers, the union locals representing the lighting, sound, camera and film trades picketed the offices and studios of WOR-TV for five weeks.

The jurisdictional dispute was finally presented to the National Labor Relations Board, which determined in August, 1975 that engineers could perform the news-gathering work assigned to them. "Engineers employed by the Employer, RKO General, WOR-TV Division, and represented by the IATSE, AFL-CIO, are entitled to perform the work of operating the electronic equipment used to edit videotape for its daily news program. . . ." the ruling stated in part.

Because of our success with ENG we disposed of our

Table I—Film vs. Videotape Material Costs

FILM		VIDEOTAPE	
10-minute 16 mm film reel	\$35	26 minute 1/4" tape reel	\$9
Processing cost	1	No processing costs	
10 minutes unedited	\$36	26 minutes unedited	\$9
Film can be used	1 time	Tape can be used	10-40 times
Usable minutes per roll of film	10 minutes	Usable minutes per roll of tape during its life	240 minutes
Approximate cost per usable minute	\$3.60	Approximate cost per usable minute	\$.04

film cameras and processing equipment and discontinued that operation. Our labor savings have been significant. It includes the elimination of our film processing and film editing operations, the reduction in the size of the field crews from three to one (plus reporter, of course) and the advantage of dealing and scheduling a single union trade.

In addition, if an engineer is not immediately required to go out on a news story, he can be assigned to any other engineering function in the station such as operating in our video tape room, performing camera or sound work in the studio, doing switching or maintenance work, and similar duties. This gives us full utilization of his time and affords us greater flexibility.

Firmer command for the news director

We have found that with ENG the news director is now in firmer command of the field crew's output. When recording on video tape, the engineer can monitor what he is recording or has recorded. The ability of the Akai VTR to back the tape up and sync onto the new material being recorded can provide a fully edited tape which can be put on the air as soon as the news crew returns to the studio.

In addition, with the electronic camera monitoring available and with the superior reliability of video tape over photographic film, we are now sure of a usable output. In the past, our news director would have to wait anxiously for the film to be processed before he'd know if he had the makings of a good story. Those days are gone. Now, even before the crew leaves the scene they know that they have a story, because they have playback facilities on location.

The significant advantages of tape over film are further enhanced when one realizes that at WOR-TV, as in most stations, 75 to 80% of the film footage taken for news stories is never used. This makes videotape, which can be used over and over again, far more economical to use than raw film stock. The difference between film and tape in terms of cost per usable minute of program material, is dramatically illustrated in Table I.

When we install our planned microwave link for direct broadcast to the studio, the news director will be in even more complete command in that he will be directing the actual shooting of the story. Here's where the lightweight electronic camera, which is carried by one man, proves its worth, because the engineer can instantly respond to the news director's instructions.

Every engineer is a cameraman

By familiarizing all of our engineers with the mini-camera, we can provide back-up personnel in case of staff illness or vacations. It also aids in providing coverage during peak news loads, such as when disasters strike, on election nights, or in sudden emergencies. With our Akai camera, an engineer can run out at any hour, day or night, and get a story in time for the next news program. If the news he brings back is urgent enough, it may even break into a scheduled show.

We transport our Minicam systems in a shock-proof padded case, which is generally kept in an automobile trunk along with extra batteries. In the fast-moving New York news environment, it's a "grab the camera and

run" situation.

Maintenance with the electronic Minicam is performed entirely by our technical staff. In the past, when the film cameras would malfunction, we had to send them out for repair. Since Minicam can be repaired by our technicians in house, we do not have a need for a "spare" camera system. The three systems we purchased fulfill our current requirements.

Quality is more than good enough to carry the show

The quality of the final tape produced by the Minicam system has more than met our needs for both ENG and other uses. The three systems are checked out each morning as part of our normal preventive maintenance and routine adjustment schedule. A sample of the picture being recorded is fed back electronically to the camera viewfinder so that the engineer may constantly monitor the camera output to maintain the desired quality. Thus he is not only aiming and focusing the camera, but is "composing" the picture and "editing" in the camera as well as in the VTR through the automatic editing control.

An important feature of the electronic Minicam over film is that the engineer has virtually complete control in the determination of the color characteristics of the picture. Film, in contrast, has its color characteristics pre-processed at the manufacturing laboratory which limits its scope. After the film has been exposed, the processor can—at best—only reproduce the color tones compounded into the raw film.

WOR-TV telecasts the New York Mets games at Shea Stadium and we have a minicamera equipped for on-the-spot interviews there. Our three outstanding sportcasters, Ralph Kiner, Lindsay Nelson and Bob Murphy conduct interviews with players, fans, celebrities, and sports officials before the game or sometimes between innings. We use an Akai camera for these interviews, and it has worked out extremely well. The interviews are then woven into the broadcast as the schedule permits.

Our Shea Stadium staff has found the Minicam to be a most effective tool in adding viewer interest to these games. If a player is hurt, we can have our unit down in the locker room area before the injured athlete gets there. If a player breaks a record or performs some other outstanding feat, we can interview his wife in the stands and put it on the air during the seventh inning stretch.

A wider door to community service

We have found that more community service events can now be covered because of the lower cost per event. This permits WOR-TV to be more responsive to the community. Because the cost was in hundreds of dollars rather than in thousands, we were able to cover an athletic event for handicapped young adults in Long Branch, N.J. We can now more readily afford to send a news crew to interview local officials in the suburbs. These programs can be interlaced with other field trips at a really low cost as compared with film.

Our experience at WOR-TV with ENG and the Minicam has convinced us that we have effected four major improvements—improved operating efficiency, reduced costs, greater immediacy, and expanded news coverage. These four advantages make electronic news gathering with the exciting new mini-camera the obvious choice for meeting the needs of our News Department at Station WOR-TV.

BM/E

Puzzle:

How do you get a lot of SWITCHER for a little MONEY?

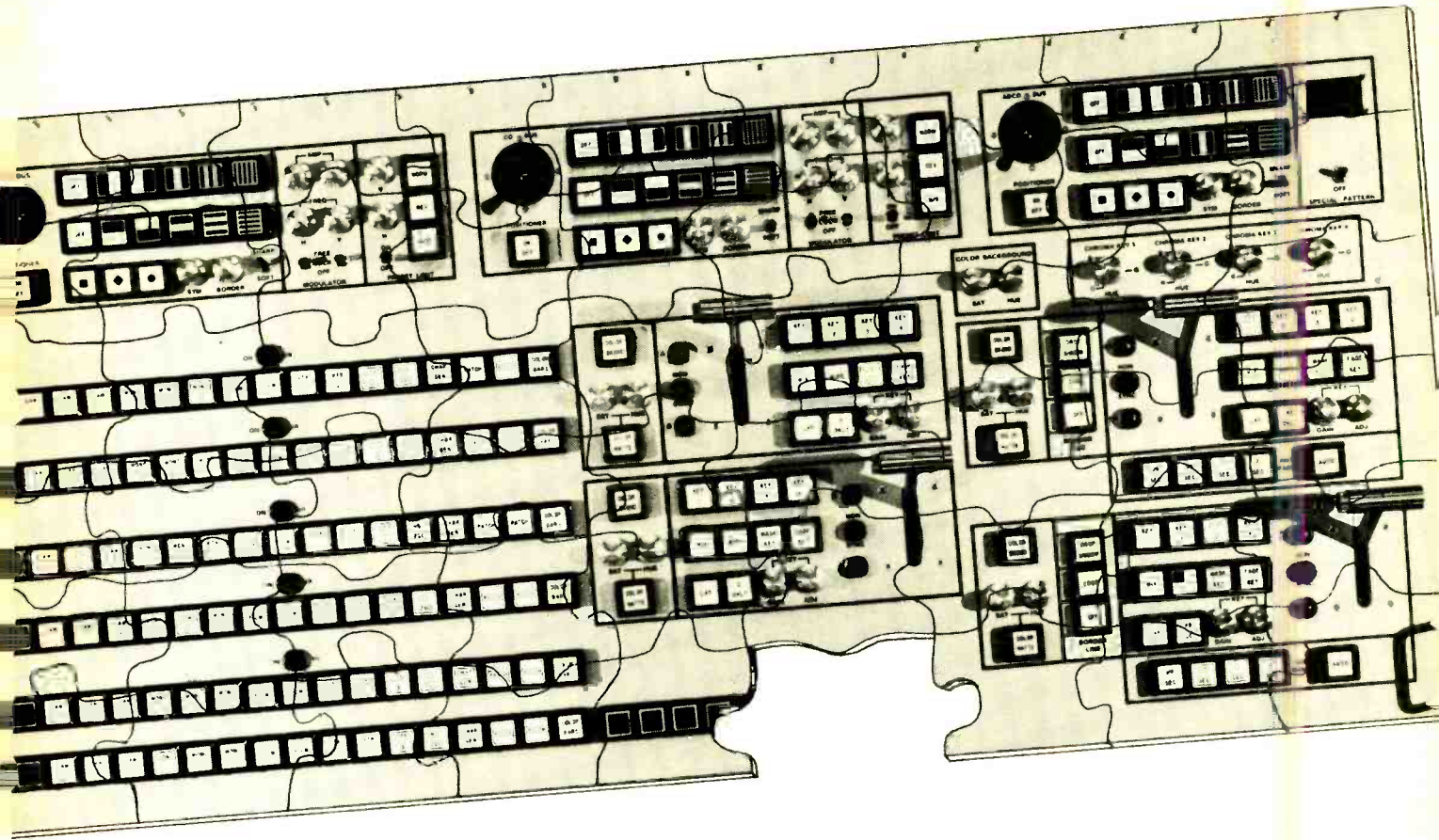

Answer: The Computer Image "Pre-wired" Modular Video Controller System.

Now there is a way to plan for the ultimate in switching potential with the least initial outlay.

If you can afford the industry's finest broadcast quality switcher with all the latest state of the art techniques and capabilities... fine! Computer Image will deliver a Model 7243 with 7 buses, 24 inputs, four mix/effects amplifiers, preview and program buses with computer compatible control, and save you money!

If however, your budget is tight, then you may choose a Computer Image Model for as low as \$10,000 — have it pre-wired for options you know you'll need and have a broadcast quality switcher today that will not soon be obsolete.

Computer Image Video Controllers are designed with circuit-element building blocks... to give you every advantage of add-on capabilities, and reliability of functions. Your basic purchase can be pre-wired for the options found in the most complete switching system.

If your future requirements can be estimated at the time of ordering a basic unit, all the add-on options can be pre-wired for only 10% of each option. And, any options ordered within six months of initial delivery will be credited that 10% pre-wire charge! The installation of any option, because it's pre-wired and completely modular, is almost as simple as plugging in the morning coffee pot!

COMPARE THE VIDEO CONTROLLER WITH ANY OTHER SWITCHER... AT ANY PRICE! Ask about price, performance, versatility, reliability, guarantee and delivery... and ask about some very happy Video Controller users!

Represented nationally by:

Broadcast Communications Devices, Inc.
1850 Warburton Avenue
Anaheim, California 92807
(714) 528-9505

Broadcast Communications Devices, Inc.
1850 Warburton Avenue, Suite 203
Santa Clara, California 95050
(408) 984-6614

Didier/Denver
P.O. Box 1599
Evergreen, Colorado 80439
(303) 674-6000

H. M. Dyer Electronics
31185 Ten Mile Road
Farmington Hills, Michigan 48024
(313) 478-2157

Landy Associates
12 Buxton Road
Cherry Hill, New Jersey 08003
(609) 424-4660

Landy Associates, Inc.
20 Winslow Street
Plymouth, Massachusetts 02360
(617) 326-6050

Radford Associates
3203 Lanier Drive
Atlanta, Georgia 30319
(404) 237-6097

The Gene Sudduth Company
2809 Raintree Drive
Carrollton, Texas 75006
(214) 242-2690



For further information call or write:
Vice President, Marketing, Video Controller Division



COMPUTER IMAGE CORPORATION
2475 West 2nd Avenue, Denver, Colorado 80223
(303) 934-5801

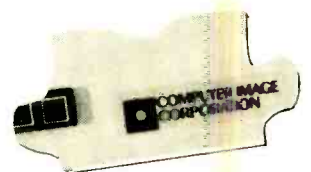

Computer Image, 1972 Emmy winner for outstanding achievement in engineering development for its unique electronic animation systems for television.

Circle 147 on Reader Service Card

At WGBH-TV, ENG Assures Realism, Keeps Newsmen Honest

Educational station uses the Shibaden SK-70 for back-of-the-news stories. Mini-equipment helps produce more mini documentaries.

Station WGBH-TV, Boston, is a pioneer public television station in using portable, but full-broadcast quality video equipment for news and documentaries. The station boasts a PCP-90 camera and an Ampex VR 3000 portable quad recorder. This equipment has helped WGBH-TV do outstanding remotes in the past but it is expensive gear and too inflexible to justify its use in a daily news operation—except for unusual situations. A



The WGBH-TV van ready for unloading in front of the Newell boat house (Harvard).

Cameraman Larry LeCain, inside van, and engineer Benjamin Krol lift out camera head hand cart. Backpack, recorder and monitors are on another dolly.

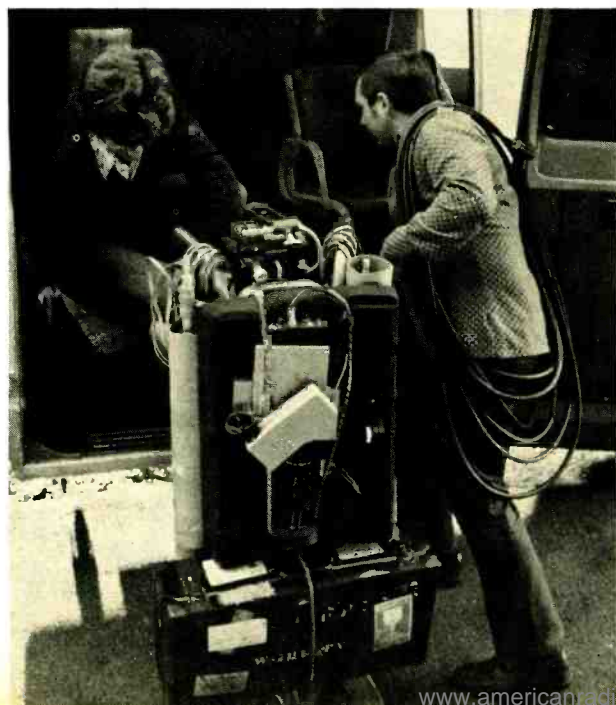

practical answer for today's needs therefore is the Shibaden SK-70 portable camera. This camera, along with Sony cassette recorders—VO 3800 portables for the field and VO 2850s for editing and playback—has become the backbone of WGBH-TV's nightly half-hour Compass show.

One of the features of the SK-70 for WGBH-TV's purposes is the fact that the camera head and back pack can be separated by up to 300 feet. This means that on many assignments the back pack can remain in the van. If this is too much of a restraint, the backpack can follow the camera head, but at WGBH-TV it need not be strapped to the cameraman. The station has constructed a video hand cart which includes not only the backpack but monitors, a Shure mixer, and the VO-3800 recorder. The station operates with a two-man crew: a cameraman and an engineer. The engineer wheels the video dolly about as needed and is on the spot to adjust controls to produce near perfect pictures.

Surprisingly, the cameraman rarely ever actually physically carries the camera head at WGBH-TV. There are two reasons: first the camera when not in use is stowed on another hand cart. The entire cart is wheeled from the van to the action scene. (The hand cart also carries the portable lighting kit and a lighting stand.) Secondly, a pedestal is used for most taping events. This is because background reporting at WGBH-TV philosophically calls for more than three minute segs. It is difficult for a cameraman to be a steady prop for long periods so pedestals are the answer.

Although the SK-70 was designed to double as a full-blown studio camera (by being able to mount the back pack on a standard pedestal), WGBH-TV does not use this option. The SK-70 is strictly a *mobile* camera.

While the station is satisfied with the camera set-up*—it is remarkably rugged and reliable says John Folsom, special projects engineer—we point out that it is a mobile system and not a portable system. The ideal, says producer director Charles Stuart, would be a truly hand-held portable unit. "I'd like to be able to send a camera into the crowds and the bleachers. Right now we can get *to* the action but not quite in the thick of it."

When maneuverability isn't a constraint, Stuart gets his video camera in close and its a better medium than film. "Its more real," he says, "some say TV stories come across harshly. I think it forces us to deal with news as it is."

continued on page 64

*We should point out the SK-70 purchased by WGBH-TV is not a standard one. It was modified to use Plumbicons rather than Saticons (normal complement) as the image forming tube. Tom Keller, WGBH-TV engineering director, felt the Saticon was too noisy for their usage.

Telemet has all 3 solid state instruments you need

to set up, test and monitor your transmitter quickly and efficiently.

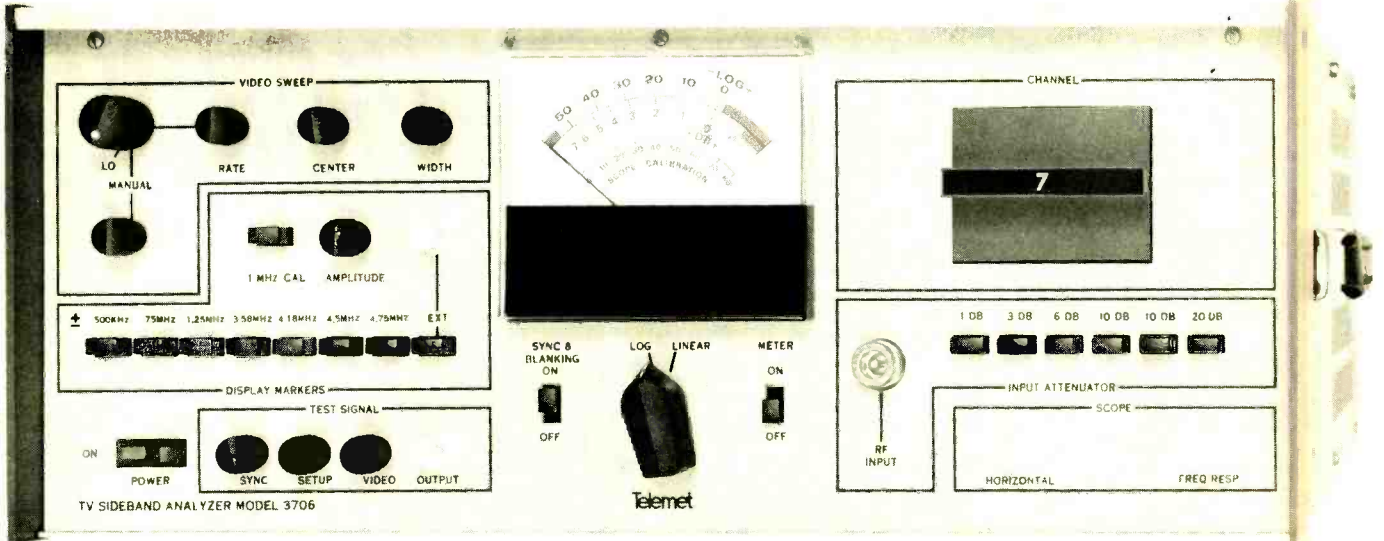

Model 3706 TV Sideband Analyzer

- 50dB Dynamic Display
- Single-Channel, Crystal-Controlled, Plug-In Tuner
- 7 Individual Crystal-Controlled Frequency Markers
- 1 MHz Comb Frequency Markers
- Variable Pedestal Control (10 to 90 IRE units)
- I.F. Bandwidth 40KHz
- Sync and Blanking Internally Added to Test Signal

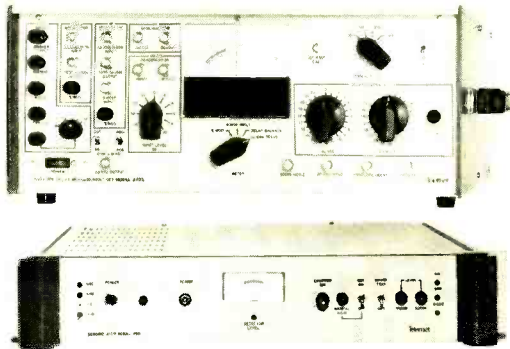

Model 3705 Group Delay Measurement Set

- Built-In Video Sweep Generator
- Test Signal Generated with or without Sync and Blanking
- Accuracy; $\pm 5\%$ of Range Used, but not better than ± 4 ns.
- Frequency Range; 0.1-10 MHz and 25-250 MHz

Model 4501 VHF/UHF Broadcast Demodulator

- 5 MV to 5 V Sensitivity
- In/Out Switchable Sound Traps
- Envelope Delay Inverse to Origination — Switchable In/Out
- Easy Measurement of Inter-carrier Frequency, Modulation Depth, and Color Amplitude

For further information, contact your nearest Telemet Regional Sales Office, or use the coupon below.

Northeast: Brewster, NY (914) BR 9-3231 **Southeast:** Atlanta (404) 633-3097 **West:** Walnut Creek, Calif. (415) 938-8887 **Midwest:** Cleveland Heights, Ohio (216) 321-7523 **Southwest:** Dallas (214) 241-0928

Telemet

A Geotel Company



185 Dixon Avenue
Amityville, L.I., New York 11701
Telephone (516) 842-2300
TWX 510-227-9850

Please send me information on the following:

- | | | |
|--|--|--|
| <input type="checkbox"/> Sideband Analyzers | <input type="checkbox"/> Modulators | <input type="checkbox"/> Pulse Distribution Amplifiers |
| <input type="checkbox"/> Video Test Signal Generators | <input type="checkbox"/> Demodulators—Fixed Frequency | <input type="checkbox"/> Clamper Amplifiers |
| <input type="checkbox"/> Envelope Delay Test Set | <input type="checkbox"/> Demodulators—Variable Tuned | <input type="checkbox"/> Monoscope Generator |
| <input type="checkbox"/> Differential Phase and Gain Measuring Systems | <input type="checkbox"/> Video Signal Conditioners | <input type="checkbox"/> Video Routing Switchers |
| <input type="checkbox"/> Remote Control Vertical Interval Test Sets | <input type="checkbox"/> Audio Monitors | <input type="checkbox"/> Video Production Switchers |
| <input type="checkbox"/> Video Sweep Generators | <input type="checkbox"/> Audio Distribution Amplifiers | <input type="checkbox"/> Chroma Keyer—RGB |
| | <input type="checkbox"/> Video Distribution Amplifiers | <input type="checkbox"/> Chroma Keyer Decoder—NTSC |

- Please send me your complete catalog.
- Please add my name to your technical bulletin mailing list.

Name _____ Title _____
Company _____
Address _____ City _____
State _____ Zip _____ Phone _____

Circle 148 on Reader Service Card



Camera set up on pedestal inside boathouse. Video dolly is on far side of camera.

Stuart cites a taping scene at a state prison. He feels film would have softened the scene whereas the TV camera showed prisoners and their surroundings in the grim detail that anyone would see were they to visit the prison in person.

While the TV camera system as used at WGBH-TV doesn't have quite the flexibility that a film camera would have, the station is getting more out of the all-electronic system for several reasons. The TV system is cheaper. Prior to its availability, the Compass program used very little 16mm film and relied on still photography for visuals. Now up to thirty percent of a show is rolling action. Says Stuart, "For every dollar I spent on film, I now spend only 50 cents. That makes a big difference for a tightly budgeted non-commercial station." As a consequence, a dollar goes further and the program is enhanced. Another advantage of video: a news crew can work in existing light. WGBH-TV was able to tape a police training session dealing with riot situations (preparing police to deal with Boston's anti-busing demonstrations) because it didn't need to turn on extra lights. Says Stuart, "If we were trying this with film, background detail would have disappeared completely. With the SK-70 we threw the 12 dB switch and got extra sensitivity. The picture was noisy but a noisy picture is better than none."

Stuart points out that while film could have been shot at a high speed for forced processing, this would have increased delays and costs since the film would have to go to a special lab.

Because the electronic system is cheaper to operate, the news crew gets around more and because it is faster,



LeCair adjusts lens opening of SK-70 camera for the scene to be taped, below.

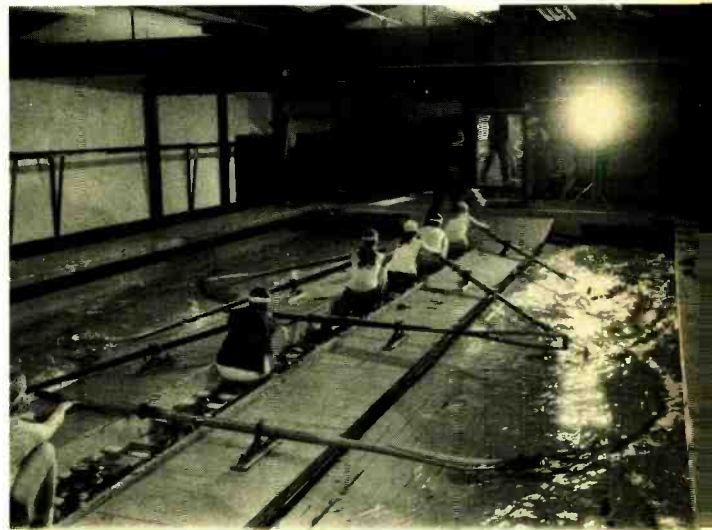

Behind the light at opposite end of skulling tank is the camera. In tank is the U.S. Women's National Team practicing for the Olympics.



In the news editing room at WGBH-TV studio. Two color monitors are used with Sony RM 400 editor.

more late news gets recorded. This, on occasion, has helped keep newsmen honest. Stuart cited a dramatic example from coverage of the anti-busing demonstrations in Boston to make his point. A particularly angry crowd had been gathered at Charlestown one day. The media was there. When the police said they were leaving at 4 pm the media lingered but not for long as the demonstrators turned their attention toward the news crews. WGBH-TV packed up quickly but it kept the camera turned on shooting through the back window of the van while exiting the scene. Excitement was high as bottles and rocks pelted the side of the truck. The temptation of a newsmen under such a siege would be to do a sensational report. But upon playing the tape back enroute to the station, the monitors showed the bombardment really came from only a relatively few youths. When the news tape rolled on-the-air an hour later, the commentator could talk about flying bottles but he couldn't call it a riot or even a violent outbreak.

A lot of the product at WGBH-TV quite properly falls in the category of documentaries rather than hard news and this might lead one to believe that speed is less important to WGBH-TV than to commercial stations. Not so. Once one works with all-electronic systems, its hard to be tolerant of film processing time. During BM/E's visit, Stuart was waiting for film to get back to him on a documentary done days earlier. He was hot to get on with the production but he was forced to bide his time. (A similar delay earlier caused a story to be scratched. In the works was a documentary on former Boston hockey star Phil Esposito. Before the film came back, Esposito was traded to the New York Rangers.)

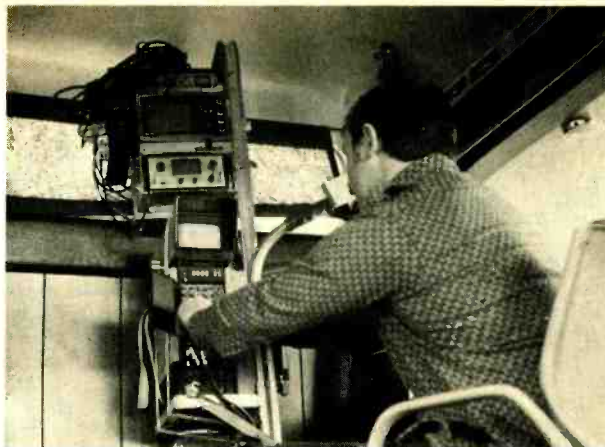

The video cart remains in the van for some taping jobs. Equipment from top to bottom: Shure mixer, five-inch Sony receiver modified as monitor (to verify color), portable Tektronix oscilloscope and waveform monitor, SK-70 backpack with standard viewfinder; Sony 2800 portable recorder; ac power pack for recorder, not shown.

Editing at WGBH-TV is done on a Sony RM 400 system. Each reporter does his own editing. The editing room is equipped with color monitors and he picks his scene from that displayed. The news crew may work with as many as six different reporters in a day. When a reporter finishes in the field he/she gathers up the recorded cassettes and heads back to the studio for editing.

Edited tapes are dubbed to quad before air-play. Folsom is considering direct play from VO 2850s as soon as he can develop an adequate cueing system. **BM/E**

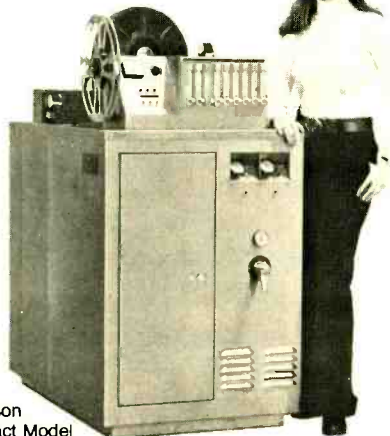

Jamieson Compact Model

Jamieson No.1 in TV!

Why is the Jamieson Processor No. 1 in TV?

The best answer is from someone who owns one.

Someone you know owns a Jamieson. Probably a lot of people you know. Why not ask them about it? The best way to get an unbiased appraisal of its performance.

Or ask us ... we'll be more than happy to tell you about the Jamieson Processors and give you references.

JAMIESON'S ADVANCED DESIGN TECHNOLOGY FEATURES

- Film advance virtually tension-free. The demand top-overdrive film transport uses no clutches, floating rollers or film sprockets.
- Smaller machines take only half the floor space.
- Solution volumes reduced 15 times over open-tank designs.
- Temperature in primary solutions is controlled to an accuracy of a few hundredths of a degree.
- The elliptical shape of the tube protects the film and provides high induced turbulence.



JAMIESON FILM COMPANY
a division of Kreonite, Inc.

6911 FOREST PARK ROAD • DALLAS, TEXAS 75235
PHONE: 214-350-1283 • TELEX: 73-0932

Please send information on Jamieson Processors and a list of some users.

Name _____ Title _____

Firm _____ Phone _____

Address _____ City _____

State _____ Zip _____ JAMIESON FILM COMPANY

BM/E-176 6911 Forest Park Rd. Dallas, TX 75235

Circle 149 on Reader Service Card

Two Remotes On Air Simultaneously With Frame Sync And Video Compressor At WTVJ, Miami.



The WTVJ remote van prowls the Miami coastline with its Ikegami cameras, Sony 3800 VTR's and Microwave Associates dish. Signals can be transmitted to the main studios or to their Ft. Lauderdale transmitting facility.



WTVJ's Electronic News Coordinator Ron Beasley directs crew traffic and monitors Sony 3800 inputs through Sony 2850 playback VTR's.

WTVJ, long ago, before ENG, built a reputation for its emphasis on remote pick-ups. They employed the conventional large scale van with five cameras and two quad VTR's. Last year they converted to contemporary ENG news gathering equipment . . . but with a twist when they added the Consolidated Video Systems CVS 600. This was the first such system ever installed in a non-network operation. The CVS 600 meant no more glitches in trying to gen lock to a remote signal. Glitches of any sort cause Tay Voyer, Director of Program Operations, WTVJ, Miami, Florida, real suffering.

Briefly, a frame synchronizer such as the CVS 600 instantly locks an incoming video signal to station sync. Networks use the unit regularly for remote news feeds from outlying cities, sporting events and it makes reception of color pictures from space a little less fantastic. ABC will utilize up to four CVS 600's in their Winter Olympic Games broadcasts.

Patching gen locks through the newscast could upset other station operations. With a CVS 600, non composite ENG inputs can be taken and chroma keyed, wedged, titled over . . . you name it, according to Voyer.

General Manager Bill Brazzil is noted for his progressive thinking. So when the technical people headed by Joe Kline, Director of Operations, said this was what the station needed, there was no hesitation. The fact that no other stations in the country had such an animal didn't bother top management. "Every live feed comes through the CVS 600"

How WTVJ uses the CVS 600 is a pretty fair example of the creative chemistry that an aggressive station can



Partially completed news screening rack with Sony 2850 VTR's and playback monitors.

Young editor compiling a decision list using a Datatron 5050 editing system. Master cassettes can be processed through a CVS 504 TBC and be used directly on-air.



generate. All three ENG crews (morning, afternoon and weekend) use Ikegami cameras for their reporting and either record in field on Sony 3800's or microwave the signal back to the station from the remote van. Crews operating in the Ft. Lauderdale area ("up the beach") have an additional option in that they can relay a signal via a fixed microwave transmitter station to the main studio for editing, dubbing or broadcasting.

In the studio, the 3/4" cassettes are edited on a Datatron 5050 and that signal is processed through a CVS 504 TBC. News directors develop their decision lists at this point and the edited masters are readied for input through the CVS 600.

As Bob Stone, Production Manager, describes it, here's where the fun begins. Every "live" signal in the station is input to the CVS 600. The program director manages and mixes this incredible variety (30 feeds

through a Vital routing switcher). He has the option of mixing several film chains, slide chains, titles, studio live, direct remote feeds from their "Live Eye," network feeds, direct remote feeds from Ft. Lauderdale, a U.S. Weather Bureau radar, quad and cassette videotape, etc. A typical news program might include three or four remotes and each would be switched on three or four times during a show.

WTVJ is a heavy user of graphics in their news reporting. A favorite composite might consist of their premier newsmen, Ralph Renick, in full frame from the studio, combined with a compressed quadrant from one of the other signal sources. To the compressed quad they often add subtitling for news effect. Clearly WTVJ has maximized its capability to communicate. "We interrupt our regular programming . . ."

In early December of 1975, Miami was the scene of a



WTVJ Microwave master pick-up and transmission system loop atop station.

Engineer at control station setting up a microwave loop with the WTVJ remote ENG van.

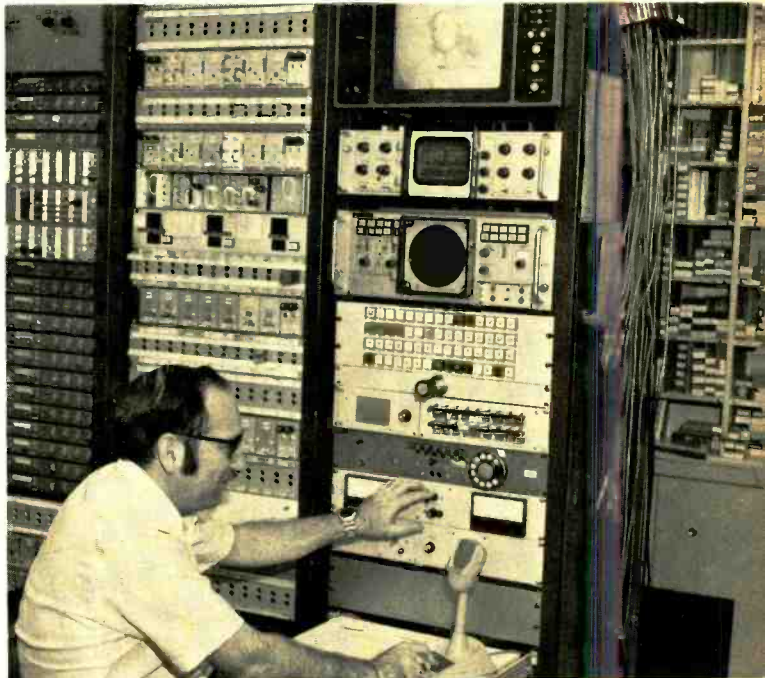

Joe Kline (left) and Bob Stone programming the CVS 600 synchronizer. Compression function is clearly shown in the monitors. Operator has a choice of six quad positions, one of the automatic positions can be reprogrammed for any "wild card" location.

Master console. Director has a complete handle on all feeds to the CVS 600 through this Vital switcher. Approximately 30 feeds from all sources, remote and station, are controlled at this point.

AUTOMATE YOUR VTR

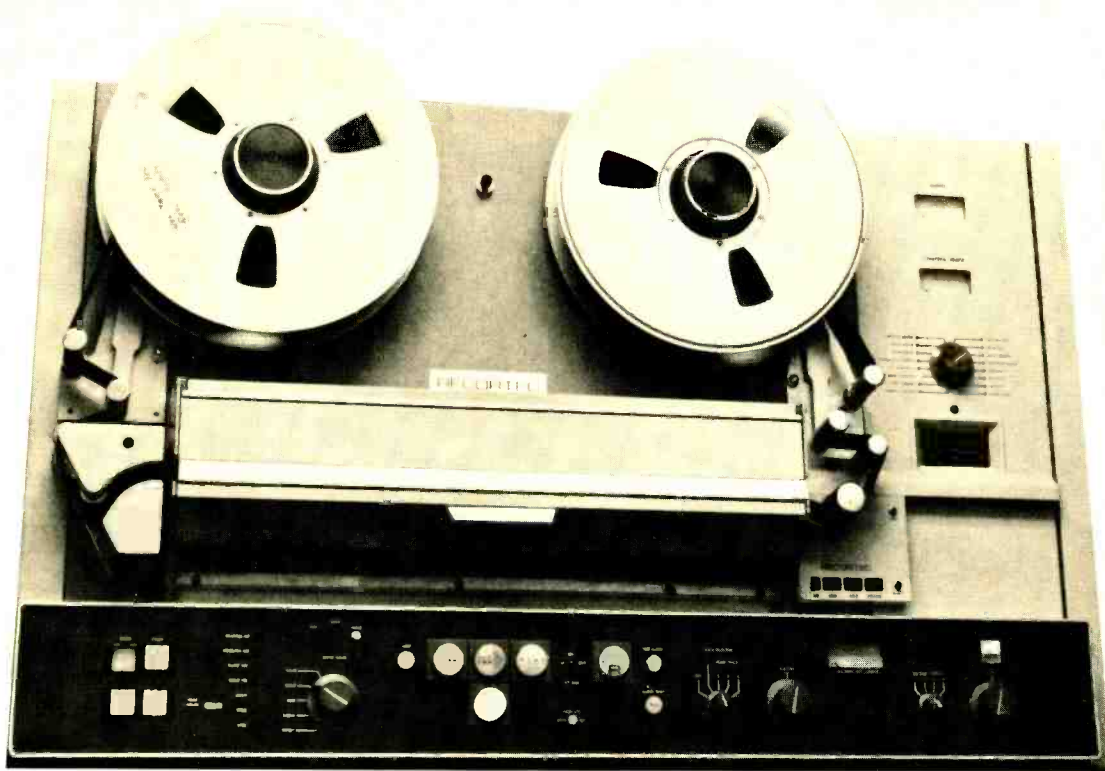

NEW PERFORMANCE WITH R-MOD

- FRAME ACCURATE ELECTRONIC TIMER
- SHUTTLE AT CONSTANT TENSION
- RELIABLE REPLAY OF CUE SIGNAL
- HANDLING OF TWO HOUR REELS
- AUTOMATIC STOP AT TAPE ENDS
- RELIABLE FOR REMOTE OPERATION
- CONSISTENT FASTER LOCKUP TIME
- INCREASED HEAD AND TAPE LIFE

R-MOD is a reel servo modification kit which consists of new DC reel motors, servo tension arm assemblies and electronic tape timer. It is easily installed in the field to provide your quadruplex VTR with superior tape handling. R-MOD rapidly pays for itself in less head wear, longer tape life and significantly more effective use of your VTR time and operating personnel.

Unless you want to buy the vacuum chamber buffered VTR, R-MOD at only \$8500 is the next best transport on the market. Before buying a new VTR, investigate the improvement R-MOD will make on your present VTR.

Want more details? Recortec is as close as the telephone on your desk. Call us toll free on (800) 586-1586. (Outside California only)

RECORTEC, INC.

777 PALOMAR AVE., SUNNYVALE, CA 94086

TEL: (408) 735-8821

TWX: 910 339 9367

Circle 150 on Reader Service Card

TWO REMOTES

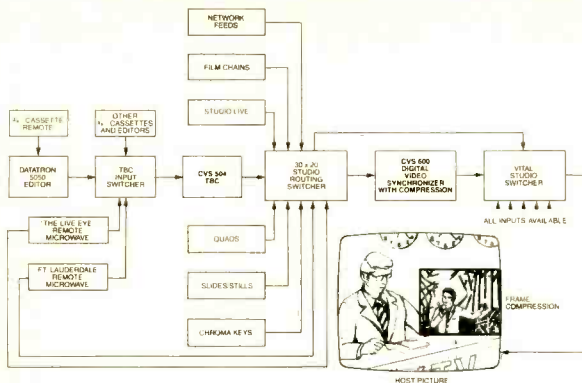

Block diagram showing frame synchronizer in system.

series of seven random "pipe" bombings. WTVJ's reporting technique heavily involved the compression feature of the CVS 600 both in regular news programming and in cut-ins to on-air programs. Host Ralph Renick would be shown in full frame. The direct remote microwave feed would be shown in compression and Ralph would conduct a joint interview with the WTVJ field correspondent. A favorite graphic treatment of the remote scene and a "hot switch" return to compression of the same scene or another feed from station sources. The net effect for viewers is one of high visual animation and interest. The net benefit for WTVJ is continued dominance of the Miami television news audience.

For other than live cut-ins, WTVJ goes direct to the air with the 2850s or it dubs one of its two ACR-25s. It's easier to use the ACR-25 because of instant audio and video. The 2850s require a three-second roll.

What's next for the CVS 600?

The station recently produced a special starring Michael Legrande. The compression feature was used extensively and became a major entertainment feature of the program. Instead of conventional split screens and the like, the program director combined many different positions of the compression feature with a variety of special graphics originating from studio sources.

Their sales department is now talking to advertising agencies and local tele-production houses. Great interest has been shown, but the station is proceeding cautiously to avoid over exposure of the technique as a "gimmick".

What the CVS 600 does for commercial production is to make available a vast source of existing film and tape materials which can now be compressed with the flick of a switch. Positioning a quadrant has until now been a matter of shooting especially for that special effect.

From the foregoing, it is clear that the frame synchronizer/compressor is used effectively. As Bob Stone says "Not every new new idea is effective . . . and we just don't mess around with those people out there." Stone is referring to the television viewers in the greater Miami area. "They're brighter than we used to think. They're on top of electronic news gathering. They know what its all about . . . and if we can use compression to be effective for the viewer, that exactly where its at."

BM/E

cut your editing down to size with Central Dynamics' EDS-200



The microcomputer Audio/Video Tape Editor for Commercial, Industrial and Educational Applications

The EDS-200 Automatic Editor and Synchronizer provides professional and economical assembly of master tapes. Utilizing its built-in SMPTE Time Code Reader, Microcomputer and program, the EDS-200 automatically locates previews and records audio and video edits accurately . . . all to a single frame.

Single button scene location, entry and storage, audio and video synchronizing and switching (in all modes), automatic cueing, and simultaneous machine control cuts the tedious and time of manual editing. The EDS-200's modular design, multi-machine control and available options allow for easy and economical expansion to meet more demanding post-production requirements.

Other features include:

- Can control several Quad Helical and Multi-Track Audio machines.
- Built-in, sensitive and accurate SMPTE Time Code Reader compensates for poorly recorded time code and can read in all modes.
- Performs Time Code duration calculations.
- Keyboard controls permit simple entry of new data, corrections or changes.
- Automatically stores scene locations from a single control.
- Audio & Video operations are selectively independent or combined.
- Fully compatible for all on-line and off-line editing operations . . . NTSC or PAL.

For the complete story on the EDS-200, Video Tape Editing and associated equipment, call or write today!



CENTRAL DYNAMICS LTD

Canada: 47 Hymus Blvd., Monrovia, Que., H9R-1G1 514-697-0811

J.S.A. 230 Livingston Street, Northvale, N.J. C7647 201-767-1300

through—at most a few blocks.

KSD-TV also invested in one of the most expensive editing systems available—the CMX-40 system with the three VCR capability. This has helped the station do some very creative mixes. Film has been mixed with ENG cassette tape by transferring the film to quad and then dubbing to the cassette. (KSD-TV has not gone to ENG exclusively.) Final on-air tape is created through an A-B roll. The computer keeps track of the decisions so the final product is achieved painlessly and quickly. Creative director Harry Honig has used the A-B roll feature effectively for news promotion. One limitation of the system is that sound from cassette A can not be mixed with a picture from cassette B without making a second pass.

As to be expected, the two ENG stations battle it out in St. Louis for a top rating in news. As we reported last year, KMOX-TV was number two until it went all ENG. It reached number one last May but slipped again when a news anchorman transferred to California. Latest sweep shows the station back in the swing again, according to Batista.

Is there a lesson here? Batista says that the *overall* news team is more important than one man and that ENG can significantly help the effort. According to Batista, “A station in third place cannot end up in first place simply by switching to ENG. ENG could be a tie breaker if there is a street fight between one and two.”

It is important to recognize that simply being able to promote ENG is a competitive edge initially for which ever system is first. An investment in Akai is probably worth while solely for its promotional value. But an Akai (or other vidicon cameras) doesn't offer 16mm quality and all other things being equal, the higher quality will pay off. There are, of course, other factors. If one can afford only one \$30,000 camera system, five \$6000 systems might be an advantage.

It is erroneous to think of news as a tape-vs-film struggle, says Batista. Essentially one must think live. The final test is in the ability of the street reporter to stand up there and deliver the news straight. “ENG is a journalists tool and not an answer,” says Batista.

Competition in Nashville

Nashville is the home of WLAC-TV. Both the station and Ralph Hucaby, VP and director of engineering, are celebrated ENG pioneers. But WLAC-TV is not alone in

ENG. WSM-TV, Nashville, is well-equipped to do a good job. Reports Lee Whitehurst, technical director of WSM: “Our mobile unit contains one Ikegami HL-35 camera, a Sony 3800 cassette machine, 1500 watts of inverted power, monitors, lights, scopes and test equipment, and at the moment a 2 watt 2 GHz microwave transmitter. We soon will have the 13 GHz window-to-truck link, and a 12 watt 2 GHz link from truck to a high rise building—or to our TV tower. We have licenses and most of the equipment is in for this.”

WSM-TV has full capability in editing by virtue of its CMX-40 system equipped with three cassette machines. The editing room is equipped with a fourth Sony 2850 for recording/playback. It is also equipped with two-way radio communications gear.

The playback record station has one Sony 2850 (soon two), two CVS time base correctors, a NEC-FS-12 frame synchronizer, two-way radio communication, cross bar switching and jack fields. The frame synchronizer permits WSM to intermix many inputs without fault.

After a year in Minneapolis-St.Paul

KSTP-TV was included in a round-up on ENG activities in March of last year. What's happened in the last nine months? A hell of a lot of activity says George Merrill, chief of engineering operations for KSTP and other Hubbard stations. Not only is there plenty of news activity, but there's a lot of outside broadcasting too. Eight major remotes have been done recently and commercials using ENG equipment are quite a growing thing. Local commercial business has gone up over 300% says Merrill.

When the object is production rather than news at KSTP, the Sony 3800 recorders are set aside and the RCA TPR-10 portable quad is used instead. Two vans can be equipped with TPR-10s. They are usually left in the truck. Auto commercials (very popular) are done at the car dealers location—and usually the talent is the dealer himself. The ability to see instantly what has been captured is valuable says Merrill. KSTP-TV can take two TRP-10s on location and do editing right in the van.

To cover the news and to fulfill a heavy production schedule, equipment must go at all times. Merrill believes in only the highest quality equipment—and equipment that can operate at 110° in the summer and minus 30° in the winter. Right now Merrill is using Fernseh KCN cameras. He has TK-76s on order and will test them out. The Editel units in use last March have been sent to Hubbard Broadcasting's station at Phoenix,



Art Shiver, KSLA-TV, doing an edit on TRI-EA 5 equipment.



KSLA-TV's John Hitt, V-P engineering, operates a Sony 2850 recorder.



KSLA-TV uses Sony DXC-1600 cameras. Cameraman is Sammie Buttin.

KOP-TV. The Editels (ENC-1s) did a good job in production but the Fernsehs are a little lighter and better adapted for news.

Both Sony and Datatron editing equipment is being used. Merrill claims that the station's operators have learned how to use the RM-400 well and it is okay for news. The station also goes directly on the air from 2850s. A news program is made up of film and ENG (approximately to a four-to-one ratio). Pre-roll time of the cassette players are adequately known, says Merrill, so that the news technical director can intermix both media well. The TD watches the preview monitor and makes the switches when appropriate.

Microwave is no problem in the Twin Cities area except for parts of St. Paul. A relay station is being built on the top of a downtown St. Paul building.

ENG in a smaller market— Shreveport, La.

BM/E talked to engineering and news people at KSLA-TV, Shreveport. As one of the first customers for the TRI editing system we were curious to find out what was happening. Here is a report from Art Shiver, chief photographer. "We currently shoot about 75% of our news assignments on video tape. Although I do not see a time in the near future when we would stop all use of film, I do feel that all of our future expansion in news photography will be in the direction of video tape. "We use Sony DXC 1600 cameras and VO-3800 recorders for field work. There is still some problem when we need great mobility or are forced to work in low-light areas. Generally, we return to film to solve these problems.

"We have one TRI EA-5 editing system which we use with Sony VO-2850 recorders. I like to have two monitors when editing; and, for this purpose, we have two Zenith color receivers which have been modified to serve as monitors. In addition, we have enhanced our editing set-up considerably by adding a six-channel custom designed audio mixer.

"We put our reporter's voice-over on the same channel as the natural sound. Thus, the edited version is the 'entire package.' This system is somewhat awkward because the Sony 2850s are not designed for this use. It would be faster and easier if channel two audio were a split track and the
continued on page 72

The new CVS 504B Digital Time Base Corrector

Our quality
is easy
to see

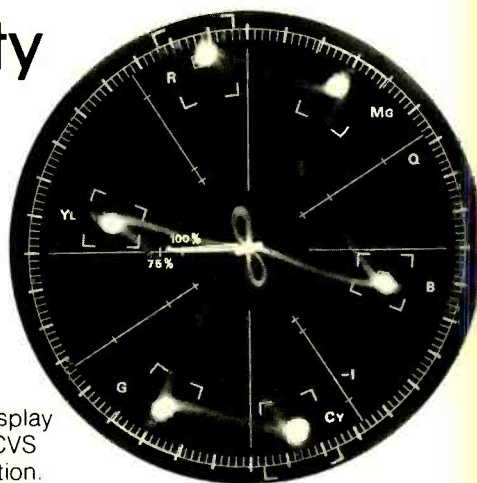

Typical Vectorscope display of VTR playback after CVS 504B time base correction.

Gyroscopic effects, when running or turning, with portable ENG systems, poor stability of tape, and chroma level instability are but a few of the real world problems of video. The CVS 504B solves these problems.

And let's look at operation and maintenance. The CVS 504B requires only front panel control in all standard operations. Every PC board requires only seconds to install. These are just two examples of our strict adherence to modular design.

Then consider the fact that CVS has delivered more than 1,200 digital TBC's. That speaks for itself.

Know what to look for when you buy a TBC? CVS can help. Just ask. We will send you a "TBC Buying Guide" to assist you in evaluating the real world of digital time base correction.

Look to the leader.



Consolidated Video Systems

3300 Edward Avenue
Santa Clara, California 95050
(408) 247-2050 Telex: 35-2028

Circle 152 for literature
Circle 172 for a demonstration

COMPLIMITER™

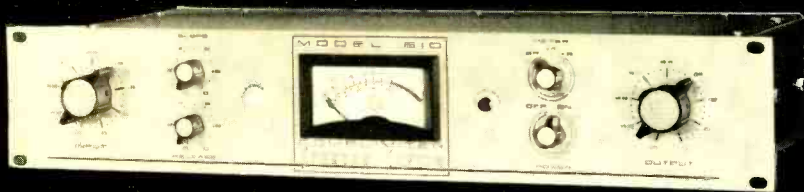

MODEL 610

Used in recording studios; disc mastering studios; sound reinforcement systems; TV, AM, FM broadcast stations to maintain a sustained average signal at a level significantly higher than that possible in conventional limiters, and with performance that is seldom attained by most linear amplifiers. Rack mounted, solid state, functional styling, the Model 610 is in stock for immediate shipment.

Specifications are available from:

SPECTRA SONICS



770 WALL AVENUE, OGDEN, UTAH 84404
(801) 392-7531

Circle 153 on Reader Service Card

ALL GO FOR ENG

reporter's voice-over could be recorded, then monitored while the natural sound and pictures are being put into proper place.

"At KSLA-TV, channel one audio is reserved for cueing. This is because a large part of the local newscast is recorded from network newscasts and there was a need for a cue tone on the tape that would cause the production switcher to switch out the tape and back to a preset studio shot.

"Now that we are replacing news film with video tape, we are having to take a second look at the design of our news photography areas. Future plans include phasing out some of the film editing stations and adding at least one more TRI EA-5 system; adding viewing-only areas for video tape where reporters can view tapes and make notes for editors; adding microwave reception areas to receive reports from mobile vans in the field. We are now installing a new 2850 in the control room."

Shiver reports some excellent production work as a result of the station owning the editor. He has been able to

MODEL 6000 Video Processing System

- Complete video processing — inserts new sync, blanking and burst
- Front panel control of video, chroma, pedestal and burst phase
- Sync generator will lock to EIA or industrial sync — works with any VTR — also operates as master sync generator
- Provides full sync, blanking and drive pulse outputs locked to input video's sync.
Subcarrier output locked to input burst
- Internal phase adjustments compensate for delays of 1 or more scan lines

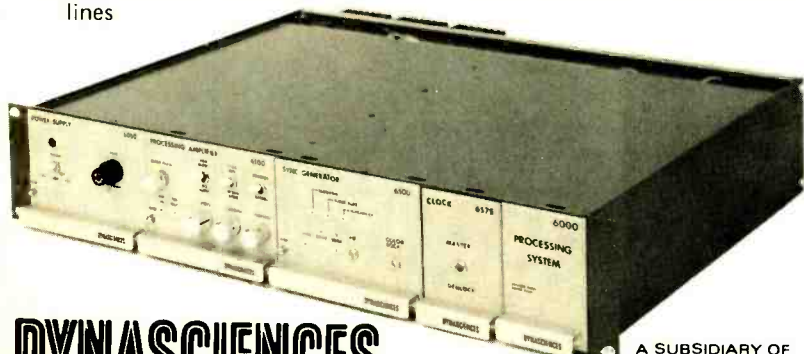

DYNASCIENCES

VIDEO PRODUCTS

A SUBSIDIARY OF

Whittaker

Township Line Road, Blue Bell, PA. Tel.: 215-643-0250/Telex: 84-6358

Circle 154 on Reader Service Card



Portable, battery-powered BCN 20 recorder from Bosch/Fernseh offers full broadcast quality.

New Time-Life Syndicated News Series Uses ENG

Time-Life's syndicated news service Money News Inserts (advice for consumers) which began Jan. 12th, uses ENG. Producing the five 1½ to 2 minute segments each week is Rebo Associates, 148 E. 28th St., New York City. Rebo uses an Asaca 3000S camera or a Sony DXC with a Canon f1.6 lens for some low-light level jobs. Recorder is the Sony 3800. Tapes currently are edited by Teletronics on CMX-300 editing system and sent out in quad format. Rebo has on order a TRI editing system.



Nurad's new Model 70 QP1 quad polarized antenna for 7 GHz.

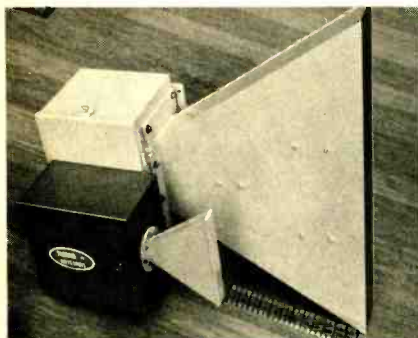

Convergence Corp.'s ECS-1 editing system interfaces with VO 2850, Akai VT-150 and other popular recorders.

do accurate audio editing which he feels is very important. Because of the fast forward feature of the editor, a producer/editor can shuttle around finding an ideal sequence of shots for an effective presentation. Shiver cited mixing long and short shots ideally in a recent documentary featuring antique carriages.

The engineering staff is not totally happy with the DXC cameras, but they are considered adequate until the station decides which of the new crop of broadcast quality cameras might be the best for them.

An interim conclusion

All in all, ENG systems are proving to be remarkably successful. Stations feel they are doing a better job than before and they find the operating cost savings significant, supporting the data presented at the 117th SMPTE conference, BM/E, December. Major cost savings, however, accrue if one switches to ENG only. Not everyone is willing to go this far. As Hugo Bondy, Chief Engineer, WAGA-TV, Atlanta, will say at the SMPTE 10th Annual Winter Television Conference in Detroit later this month (Jan. 23-24), "Anybody who thinks they can do everything with ENG as they now do with a film camera is off their rocker." ENG systems are not flexible enough to get the best shots of natural disasters such as fires unless they also have a helicopter.

BM/E

IGM's RAM - runs like a Tiger and thinks like a Fox -

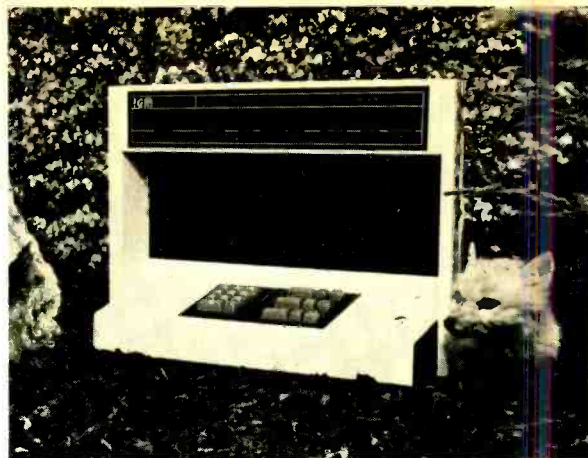

RAM these new capabilities into your existing automation system:

- 2048 or 4096 switching events
- up to 19 audio sources, each with 79 sub-sources
- random access direct addressing to all sources
- "look-ahead" advance search
- flagged event editing
- multiple audio overlap
- event link, cancel-back, and time update
- exclusive IGM Audabus chassis
- simple installation—simple operation
- operates as a "main brain," too
- WORKS WITH ANY AUTOMATION SYSTEM
- would you believe all this, and much more, at a realistic price you'll love

Call or write today for full information. You may just prevent your present system from becoming an endangered species.

IGM

a division of NTI

IGM's Random Access Memory—automatically
... the best there is!

4041 Home Road • Bellingham, WA 98225
(206) 733-4567

Circle 155 on Reader Service Card

MC MARTIN announces LOW FM MONITOR PRICES

FM MODULATION TBM-3500B



with STEREO or SCA (TBM-2200A or TBM-2000B) \$2,625.00
with STEREO and SCA (TBM-2200A & TBM-2000B) 3,950.00
for "OFF-AIR" drive, add the LL-35B 180.00

FM MODULATION and FREQUENCY TBM-3700



with STEREO or SCA (TBM-2200A or TBM-2000B) \$2,810.00
with STEREO and SCA (TBM-2200A & TBM-2000B) 4,135.00
for "OFF-AIR" drive, add the TBM-2500C 533.50

Compare features and prices and call

McMartin

4500 South 76th Street Omaha, Nebraska 68127 (402) 331-2000 telex 048-485
Circle 156 on Reader Service Card

BROADCAST EQUIPMENT

For more information
circle bold face numbers
on reader service card.

Carrying system for portable VTRs incorporates a cantilevered camera arm which allows the camera to be swung aside when not in use. The camera plat-



form adjusts both up and down as well as forward and backward from the eye. The PB-10 accommodates the Sony AV-3400 and the Panasonic NV-3082 decks without modification. \$164.95 K AND H PRODUCTS, LTD. **300**

Time base corrector for any helical scan VTR, the TBC-110, offers Internal or External sync selection, Direct or Het color correction, H lock or Line lock recorder selection, and Process or

Phased output chroma selection. Dual outputs on sync and individual timing adjustments on Sync, Blanking, H drive and Burst Flag provide advanced or delayed pulses. Residual jitter is ± 17 ns monochrome and heterodyne correction modes, ± 4 ns direct color mode. EDUTRON **301**

Sapphire-bladed module for video tape cleaning uses a four-edged cleaning post. Called The Tape Saver, the cleaner is equipped with a vacuum system for continuous blade cleaning, cap screw for blade rotation, and is designed to adapt to almost any tape cleaning machine. A module kit with one four-edged sapphire blade costs \$650. THE VIDEO TAPE CO. **302**

Slide synchronising kit for Revox A700 is used on conjunction with the remote control to record synchronising pulses on the tape in addition to stereo program material. A pilot head records the pulses in the center guard band on half-track systems and in place of track four on quarter-track systems. A built-in relay provides contact closure to operate external equipment. The kit, part no. 73837, costs \$83.25. REVVOX **303**

Changing bag for film features an aluminum carrying case with inner double layer of rubberized cotton and an outer layer of polished cotton. Elastic arm bands and a light-tight door prevent light from entering bag. Access area is 18" x 13" x 28"; weight is ap-



proximately 6 lbs. MATTHEWS STUDIO EQUIPMENT, INC. **304**

Color broadcast camera, the BCC-3, features a cast aluminum camera head case making it adaptable for both studio and on-location environments. The BCC-3 uses three 1" Plumbicon tubes, including one for extended red. A Schneider f2.5 10:1 zoom lens is stand-

ard with 15:1 and 20:1 zoom lenses optional. The small-diameter camera cable can be run as far as 1,000 feet with no timing adjustments necessary. Delivery is estimated to begin early in 1976. \$55,000. AMPEX **307**

Tie clasp electret condenser microphone comes with a tie clasp, battery, 13-foot attached cable and transformer

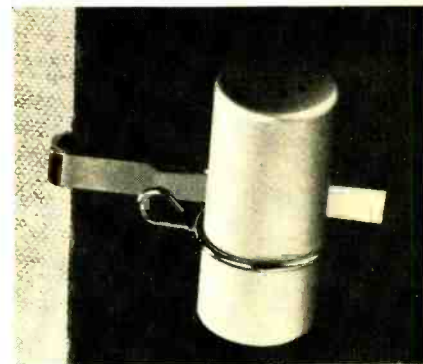

and 3-pin connector. Model MC-325 is for use with low- or medium-impedance amplifier. \$45. SESCOM. **305**

Antenna current instruments are substituted in applications where conventional thermocouple meters are ordinarily used. The Models TCA and

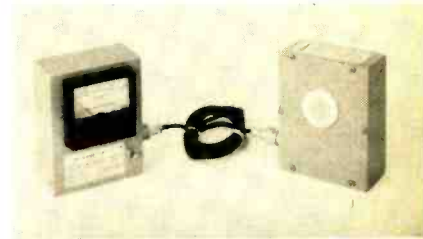

TCA-XM meet FCC requirements of 2% accuracy. The meters are calibrated at broadcast frequencies. The instruments are available in 5 ranges up to 80 A. DELTA ELECTRONICS **306**

Interchangeable 12.5-75 mm macro zoom lens is available in the following mount systems: C; Arriflex; new Arriflex; Eclair, and type CP. Lightweight 6x lens focuses as close as 3 1/8" from its front element. Optical dollying and continuous rack focusing from extremely close to distant subjects is possible. The lens changes its focal point while maintaining constant field size. CANNON U.S.A. **308**

Automatic channel monitor/recorder for CCTV, Model ACM, is used to test long-term AGC/ASC response vs.

continued on page 76



CINEVID-16.
Sherwin Greenberg will never shoot another TV commercial without it.

His clients won't let him. Because with CINEVID-16 they get all the advantages, the quality and versatility of 16mm film *plus* the immediacy of video tape.



Sherwin Greenberg is a veteran TV commercial cinematographer and documentary filmmaker. He is also president of Greenberg-May Studios (Buffalo, NY) — and a shrewd businessman to boot. His two CP-16R reflex cameras are equipped with CINEVID-16 video-assist systems. They are both kept constantly busy. And earning rave notices from ad agency clients along the way.

"I just can't imagine going back to shooting a commercial on film without the video viewing. From the agency/client point of view, the system gives you unrestricted view of every take, just the way the camera sees it, without getting in the way of the film crew or constantly peering through the camera lens to see what's happening. . . . It also helps the talent to make instant corrections in the acting and delivery. This factor alone should save shooting time — and film costs — every time people use the system."

N. T. Smith, VP & Creative Director (Lloyd Mansfield Co. Inc.)

" . . . watching exactly what was being filmed and playing each scene back on the closed-circuit monitor answered many questions before they were asked, and revealed any possible problems before they became problems."

M. R. Slepian, Radio/TV Production Director (Weil, Levy & King Inc.)

Our CINEVID-16 system makes video-assisted filming a simple option rather than the complex and cumbersome operation it used to be.

The CINEVID-16 video-assist camera is extremely compact and lightweight. Quick and easy to attach to or disconnect from the CP-16R camera. It picks up the image directly from the CP-16R fiber optics viewing screen and transmits it to any number of remote monitors and/or video tape recorders (for "instant dailies"). With virtually no loss of visible light in the CP-16R reflex viewing system. Optional CINEVID-16 system accessories include a video control console (with three monitors, plus dissolve and wipe controls), a crystal controlled sync generator, etc.

Whatever you're shooting — documentaries, television commercials and specials, or other 16mm film assignments — you'll find CINEVID-16 an ideal video monitoring aid in the studio as well as on location.

For further information, please write to:

Cinema E products
 CORPORATION
Technology In The Service Of Creativity
 2037 Granville Avenue, Los Angeles, California 90025
 Telephone: (213) 478-0711 ■ Telex: 69-1339 ■ Cable: CineDevco

Circle 157 on Reader Service Card

PRODUCTS

time and temperature change, for observing and recording system balance, and for accomplishing FCC-required signal level measurements and recordings. Each channel is programmed to be sampled via front panel pushbuttons and will handle up to 30 channels. A meter is provided for everyday level



tests; manual cycling through the channels offers a 2.5 sec read-time, alternated with a 2.5 sec reference signal. The total dynamic reading-range is 40 dB or 20 dB at three scale settings of -10 dBmV, 0 dBmV and +10 dBmV. COMSONICS 309

Computer controlled automation system, the DP-2, is microprocessor



controlled, self diagnostic and offers 4K or 8K of event capacity, built-in external function control, automatic transmitter logging option, mag tape, paper tape and solid-state storage facilities. SMC 310

Lighting controller, The Sonalite

Four, operates four channels at 200 watts/channel (at 120 Vac). Each channel is individually adjustable together with auto switched progression, auto fade progression, sound progression and sound sync. Accessories include expander capability (2 kW each per channel!) together with an optional manual keyboard. \$1,275. METEOR LIGHT AND SOUND CO. 311

Video digitizer, the Model 270, accepts standard CCTV signals and converts video information into 8-bit digital format for computer input. A picture of 480 x 512 elements may be digitized with direct computer addressing of any point on the TV screen. A standard monitor is used to reconstruct computer processes images via photographic time exposure. \$4,000. COLORADO VIDEO, INC. 312

Pedestal-mounted telcine projector, uses dual drum for 35mm or 2x2 lap dissolve. The Model 4205, offers 160 slide capacity and 48-in. optical centerline. Solid-state lap-dissolve electronics can be adjusted to provide transitions ranging from quick-cut up to 12 sec duration. Projection lens (f/5) provides image sizes ranging from 1.6" x 2.1" to 2.25" x 3.0". Remote control is optional. \$1,595. ZEI-MARK 313

Single-channel mid-band converter-descrambler, designated the DST-1C, converts and descrambles channels H or I to channel 3. It is field-retrofittable to allow descramble operation in conjunction with a standard set converter. JERROLD ELECTRONICS 314

Crystal control unit for Scopoc type 16M 16mm camera gives the filmmaker the ability to shoot sync sound. The solid-state module mounts on the camera accessory shoe; all power is derived directly from the camera. Modification of the 16M is required for use with the unit. CANON, U.S.A. 315

Quadraphonic type CD-4 demodulator kit uses an LSI chip developed by Quadracast Systems, Inc. The kit interfaces between the phono cartridge and the four discrete inputs of any quadraphonic system. The demodulator handles standard magnetic cartridges and a semiconductor cartridge manufactured by Technics/Panasonic (Model EPC-451C). The cartridge can be purchased with the kit for \$25. A switch on the rear panel allows stereo discs to be played as well as CD-4's. A special test record, developed as part of this package, is available at an additional cost of \$5. SOUTHWEST TECHNICAL PRODUCTS CORP. 316

Headphones are available either in a stereo double phone version or single side. The headphone has a frequency response of 50-15,000 Hz and an impedance of 200 ohms (optionally 6,000 ohms). The headphone weighs 8 oz. and is fabricated from nylon plastics. It has a steel headband with padded cover and tinsel cable. TELEVISION EQUIPMENT ASSOCIATES 317

Dual drum 35mm lap-dissolve slide projector, the Model LD-4200, uses pellicle beam splitter. Lens of 9-in. focal length projects an image size range of 1.6" to 2.25" high. Local control provides Change, Adjustable Dissolve Rate and optional Auto-Timer modes. Remote change control is optional. \$1,350. ZEI-MARK CORP. 318

Mixer/preamplifier, the Model 5880,

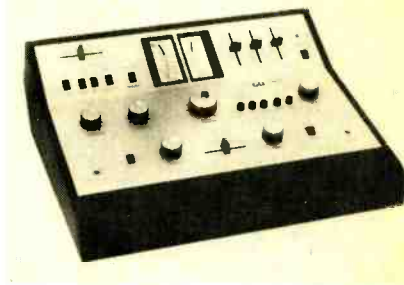

Still the industry's MOST DESIRED

VIDEO TAPE EVALUATOR



- Tape evaluation at 16 times speed
- World wide customer base
- Standard in the industry
- Leasing program available

RECORTEC, INC.

777 PALOMAR AVE. SUNNYVALE, CA. 94086 TEL: (408) 735-8821 TWX: 910 339 9367

Circle 158 on Reader Service Card

is designed for disco use. Two primary inputs accept either phono or high-level stereo signals. A universal-impedance mic input feeds both stereo channels and an auxiliary stereo input is available for a tuner, tape player, or other high-level sound source. Each input has an individual level control. An RG peak limiter/downward expander is used to restore dynamic range to recordings. A tri-band equalizer is included. \$600. GLI **319**

Color monitor is offered with 12" Trinitron CRT. The Model VM-12PR features A-B inputs, dc restoration, tally light, individual RGB switches and chroma on-off control. \$1,050. VIDEO-TEK **320**

RF interference filter/voltage transient suppressor offers RF interference attenuation of 60 dB for pulses superimposed on normal ac line voltages. The unit is capable of withstanding current surges on the order of 2000 A. Load currents of 15AA (at 117 Vac) is the normal rated capacity. BOSTON SOUND **321**

Lighting stands and accessory line, called the Great American Stand, includes eight stands and light booms, cables, lite tites, caster sets and weights. Bent leg stands are featured in either standard anodized aluminum or anodized black finishes. Other stand models fold into a 21" package. THE GREAT AMERICAN MARKET **322**

Color monitor/receiver, the Model JU-970W, is equipped to accept RF or bridged direct TV video and audio line feed. There is also a separate 75-ohm video output for direct off-air recording. RCA SERVICE CO. **323**

Color camera sync coupler, Model GK-2000U, simultaneously provides two JVC type GC-4800U color video



cameras with the same color sync signals. One internal and three different external types of synchronization are available. Internal sync provides HD, VD, Sync, SC, BF and Blk. Two independent phase compensators are built in. JVC INDUSTRIES **324**

Television character generator is plug-compatible with the Sony Video-Rover 1/2-in. portable VTR series. The K128S is self-contained and portable, but requires 115/230 Vac power. Titles or full pages can be added to Sony tapes



permanently while recording or transcribing, or mixed downstream with Sony tape or camera outputs. \$3,250. KNOX **325**

Double-system sound camera, the Model CP-16R/DS, is identical to the standard CP-16R reflex camera except that the flywheel and film threading

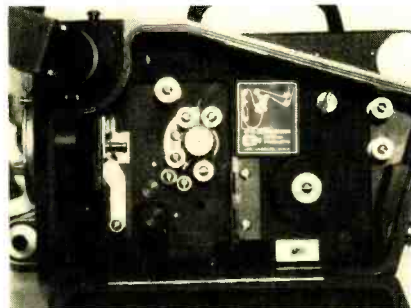

rollers needed for single-system sound recording have been removed. The CP-16R/DS can be converted to single/double system sound capability. CINEMA PRODUCTS **326**

Color monitor, the Model UMT-1206, features a 12-in. one-gun color crt. A built-in speaker amplifier provides audio monitoring. Standard features include: loop-through BNC connectors with termination switch; parallel connected 8-pin plug for VTR monitoring. Pulse cross is provided as an option for viewing the vertical and horizontal display of sync, burst, blanking, test and reference signals. \$525. UNIMEDIA **327**

Studio color monitor, the Model SMT-12, features full-view tally identification, A-B electronic video selection, internal-external sync selector switch, keyed back porch clamp with full dc restoration and variable aperture control. The 12-in. monitor also features front panel doors for concealing secondary controls which include RGB background adjustments and variable aperture control on the monitor right side. \$945. UNIMEDIA **328**

Color-coded labels are self-sticking. They are pre-printed with the type of program material and space for title and date information. The labels are available in five-color sets or in individual colors. TELE-MEASUREMENTS **329**

Arabic language character controller, Model Q620, generates 64 continued on page 78

COLORBARS & a VECTORSCOPE GO HAND IN HAND

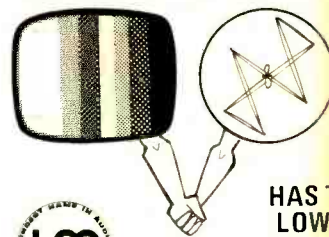

HAS THE LOWEST COST ARRAY EVER

- ★ The VM3 NTSC VECTORSCOPE
- ★ R/BS9 Complete NTSC SYNC GEN. (2 sets of outputs) with Genlock & COLORBARS GENERATOR
- ★ R/DB8 Driven Encoded COLORBARS GENERATOR
- ★ R/GB8 Standalone Encoded COLORBARS GENERATOR
- ★ R/CS2 NTSC SYNC GENERATOR (2 sets of outputs) with Genlock
- ★ All units are portable and rack-mountable, and include self-contained power supply.

Ultra Audio Products

BOX 921 BEVERLY HILLS, CALIF. 90013
(213) 276-2726

Circle 159 on Reader Service Card

NEW Matthey Video Delays SERIES 5-25

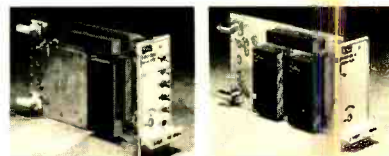

Features

- ★ Range 10-2120ns
- ★ Panel mounted ± 4 ns vernier provides precise timing
- ★ Equalized to 5.5 MHz
- ★ 8 video delay cards accommodated in 5 1/2" rack frame
- ★ Available with or without switches
- ★ In-field modification of delay range to meet changing requirements
- ★ Saves time, money and space

Television Equipment Associates, Inc.

BILL PEGLER 516 • 628-8068
Box 1391 • BAYVILLE, N. Y. 11709



Circle 160 on Reader Service Card

PRODUCTS



Arabic characters, including numerals and upper and lower case, allowing the

user to transcribe the Arabic language in an 80 character × 24 line display format. The display is written from a 5-level CCIT serial data source at 50 baud. Data is refreshed from an internal memory at a rate of 50 Hz and remains stored and displayed until changed by the data source. Video output is compatible with EIA-standard video monitors. Character size is .09" × .22". \$2,325. ANN ARBOR TERMINALS 330

Time base corrector, vertical interval switcher and a color sync generator have been added to a line of color video equipment. The three com-

ponents are designed for use with Akai VTS-150 and VTS-150B portable color video systems. The time base corrector, model TBC-150, removes transport distortions present in helical-scan VTR's. The vertical interval switcher, Model SEG-161, enables preview and/or preset of mix or effect without disturbing the program output. The SEG-161 costs \$2,995; the TBC-150 retails for \$3,495. AKAI 331

Videocassette playback system, the Cine-Matic II, consists of Model 1024 automatic digital program controller, 2 JVC CP5000U videocassette players, Model 2020 audio/video modulator. It is suitable for adjacent channel use and is available in any VHF TV frequency, plus sub-band and mid-band channels at no additional cost. UHF channels can be provided at additional cost. TELE-MEDIA ELECTRONICS 332

Seven video equipment products: Model P-50 processing amplifier; bridging video switcher; color bar and sync generator; digital video AGC unit; three distribution amplifiers. The proc amp generates a pulse-cross format with automatic brightening. It accepts all sync formats. The vertical interval bridging switcher provides switch-position memory during momentary power failure. The color bar/sync generator provides the NTSC 8-bar pattern and all studio synchronizing

**From 80 years of experience
comes the finest AM & FM
Broadcast Transmitters
ever manufactured.**



CSI ELECTRONICS INC.

2607 River Road
Cinnaminson, New Jersey, 08077 Telephone: (609) 786-1060

Circle 161 on Reader Service Card

READY!

LPB's [®] mini-studio systems come complete and ready for on-air, recording studio or remote operation. Every system is tops in value . . . unmatched even by higher priced systems! Included are:

- Console.
- 2 Professional 3-speed 12-inch Turntables.
- 2 12-inch Tone Arms.
- 2 Stanton Cartridges with styli.
- Turntable Equalizer/Preamplifier . . . 2 for stereo.

There's a full range of complete systems to choose from . . . each with sturdy, handsome, white Formica® top furniture over chromed steel legs and supports.

LPB offers a complete line of broadcast audio equipment. Call or write us for all your audio needs, from mike stands to headphones.

LPB[®] LPB Inc.
520 Lincoln Highway, Frazer, PA 19355
(215) 644-1123

Circle 162 on Reader Service Card

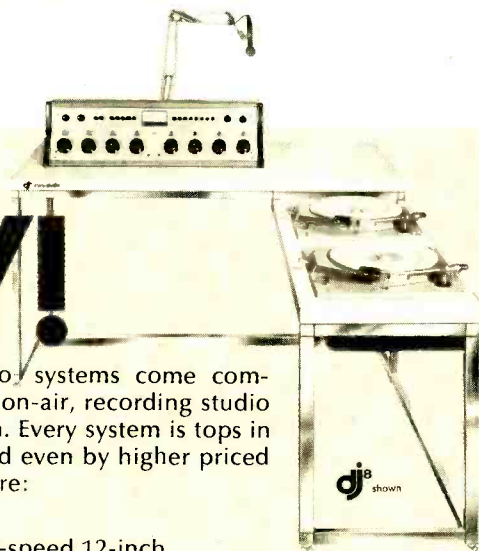

signals, as well as a test tone for audio system checkout. The digital video AGC unit has selectable attack and release time, a peak-white or VIR reference signal, and a fade-to-black recognition signal. 3M CO. 333

Video-audio level stabilizing amplifier, Model AMC-1272, accepts TV signal of varying amplitude and provides optimized picture and sound to any TV modulator or VTR. \$475. FUNG ENGINEERING 334

Portable lighting control package, the Kliegpac 9, comes with nine 2,400 watt dimmers, integral split fader with manual timed fades and expansion by channels and presets. KLIEGL BROS. 335

Variable-speed, crystal-controlled ACL motor conversion is available for Eclair cameras with MIALA-type motors. It provides crystal-controlled speeds of 24 and 25 fps, plus variable speeds of 8 through 48 fps. \$750. CINEMA PRODUCTS CORP. 336

NEW LIT

For copies of these literature offerings, circle number for appropriate items on Reader Service Card.

Legal Problems in Broadcasting, a reference book on broadcast law authored by Daniel W. Toohey, Richard D. Marks and Arnold P. Lutzker, is now in its second printing. The text is used by communications arts students throughout colleges in the United States. Some chapter titles include: Defamation, The Right of Privacy, The Fairness Doctrine and Personal Attack Rules, Political Broadcasting, News Staging, Obscenity, Violence, Copyright, Unfair Competition, and Lotteries. The text is available in either a hard-bound (\$8.75) or soft cover (\$5.95) edition and may be ordered from Great Plains National, Att'n: Special Products, Box 80669, Lincoln, Nebraska 68501.

Basic Digital Electronics—Understanding Number Systems, Boolean Algebra, & Logic Circuits is a reference offering explanations of digital circuits, number systems, Boolean

algebra, all popular logic systems, and a section full of digital building block concepts. The hardbound edition costs \$7.95 (\$4.95 in paperback). Tab Books **250**

A brochure describes the Model 8003 **video satellite earth receiving terminal**. The component parts of the terminal and specifications for the receiving equipment is covered. Scientific-Atlanta, Inc. **253**

A 36-page brochure shows how to **test two-way radio systems** in 35 different ways. Each test includes: a set-up diagram, a brief summary of the technique used in the test, a list of test equipment required and a step-by-step test procedure. Singer **254**

The first edition of the quarterly Production Managers Association newsletter—**PUNCH**—is available. The newsletter's name alludes to the original verbal cue voiced by the director when calling for camera shots. If you're interested, write to Alvin A.L. Dompke, PMA Newsletter Editor, WBNS-TV, 62 E. Broad St., Columbus, Ohio 43215.

An illustrated, six-page brochure details the features of the **LDH-16 color telecine system**, a compact video program origination/production

continued on page 82

Phone 601-675-2956



Tower Painting by

PROFESSIONALS will give you a BETTER JOB at a LOWER COST with no extra problems.

We paint all year round day in day out. Tall towers — Congested areas — fragile Antennas given special consideration.

Let real experience simplify your painting requirements

Dave Hovey
General Contractor
Coffeeville, Miss. 38922

Tower Sales — Site Preparation Rigging — Maintenance Modifications — Consultation

Circle 163 on Reader Service Card

Beau. The only quality replacement motor for cartridge and reel-to-reel tape machines.

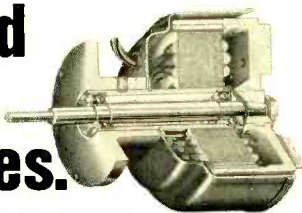

Ever wonder why the unique Beau, inside-out, hysteresis synchronous tape drive motor is specified in just about every major piece of cartridge tape equipment? Or why so many Ampex and Scully machines are equipped with Beau replacement motors? The answer is simple: Quality. Beau offers unbeatable operating specs, outstanding reliability, long life, quiet operation, compact size, and unconditional factory support. No import can beat Beau, the original broadcast tape drive motor.

To order Ampex and Scully replacements, specify tape speed and model number from the table below:

Type and Models	Beau Prices
Ampex — Model 440	\$180.00
Ampex — Models 350, 351, 354	\$195.00
Scully — Models 270, 275, 280, 282	\$180.00

For fast delivery of cartridge drive motors for ITC, ATC, Gates, Spotmaster, Ampro, and Sparta machines, call (203) 288-7731. Or write for our free Beau motor bulletin.

UMC[®] BEAU MOTOR DIVISION
UMC ELECTRONICS CO.
460 Sackett Point Rd. North Haven, CT 06473

Circle 173 on Reader Service Card

From 10 to 1000 or more tapes a day

you get clean like-new erasures on a Model 70.

Designed for professional and commercial users concerned with quality and production speed, the Model 70 pays for itself quickly on both. Erases up to 7" reels, audio cassettes and video cassettes. Unique belt transport is key to rapid erasure cycle.



GARNER INDUSTRIES
4200 N. 48 St.
Lincoln, NE. 68504
402/466-1816



Circle 164 on Reader Service Card

BM/E CLASSIFIED MARKETPLACE

CLASSIFIED ADVERTISING RATES

DISPLAY CLASSIFIED ADVERTISING: \$32.50 per inch 1x; \$30.00 per inch 6x; \$27.50 per inch 12x. ALL OTHER CLASSIFIED ADVERTISING 35¢ per word; minimum \$3.50. BLIND BOX NUMBER: \$1.00 extra charge. Replies sent to address below will be forwarded to you. PAYABLE IN ADVANCE; send check with order. CLOSING DATE: 5th of 2nd month preceding issue date.

BM/E, Monterey and Pinola Avenues, Blue Ridge Summit, Pa. 17214 Phone 717/794/2191

EMPLOYMENT OPPORTUNITIES

TV MAINTENANCE TECHNICIAN

A major eastern market quality conscious TV operation is looking for that unique, logic minded technician to fill a vacancy in our maintenance department. This well-paid, challenging position is a rare opportunity to work in a self-fulfilling job, in a people oriented atmosphere. An equal opportunity employer. Box 1275-1, c/o BME, Blue Ridge Summit, PA. 17214

FIELD SERVICE ENGINEER

Extensive Travel. All Benefits. Experience in Color video and switching systems preferred. Contact: **Mr. Buzan, Vital Industries, Inc., 3700 N.E. 53rd Avenue, Gainesville, FLA. 32601 Phone: (904) 378-1581.**

EQUIPMENT FOR SALE

45% OFF

in any quantity on Stage, Studio and TV Production Lamps. Complete Stocks. Rapid Service.

SITLER'S SUPPLIES, INC.

215 N. Iowa Ave. P.O. Box 10-M
Washington, Iowa 52353
Phone (319) 653-2123.

ENG EDITING PACKAGE. 1 - New TRI-EA5 Editor with 1 - IVC 870C and 1 - IVC 825C (VTR's used, but with new head and new machine warranty). Complete package \$10,000. All items available separately or as a package. J.D. Ivey Corporation, 617 West Central Blvd., Orlando, FL 32801. (305) 843-8982.

Broadcast mixer for remote out of studio programming. Can be used as inexpensive second console for college and small radio stations. D.J.'s can now originate programming at home. Simultaneous mixing of two stereo phonographs, a tape machine and a microphone. Precise for all inputs with built in monitor headphone amplifier. Send for literature. \$325. Professional discount, use letterhead. GLL Box 2076, DEPT BM/E, Brooklyn, N.Y. 11201 Phone: (212) 875-6992.

Solid-state audio modules-console kits, power amplifier kits, power supplies, Octal plug-ins, mic. eq. line, disc, tape play, tape record, amplifiers. Audio & tape bias oscillators. Over 50 audio products. Send for free catalog and applications. Opamp Labs, Inc. 1033 N. Sycamore Ave. Los Angeles, Calif. 90036. (213) 934-3566.

SUPER EDITING PACKAGE, featuring 1 - IVC 960, 1 - IVC 900, 1 - TRI-EA5 Editor, and 1 - Microtime Time Base Corrector. Complete package \$26,000. VTR's are used but completely reconditioned with new scanners and heads. Microtime TBC used. TRI Editor new. J.D. Ivey Corporation, 617 West Central Blvd., Orlando, FL 32801. (305) 843-8982.

AMPEX, SCULLY, TASCAM, all major professional audio lines. Top dollar trade-ins. 15 minutes George Washington Bridge. PROFESSIONAL AUDIO VIDEO CORPORATION. 342 Main Street, Paterson, N.J. 07505. (201) 523-3333.

AEL DFM Exciter and stereo generator. In excellent condition. Removed working for replacement by new generation equipment. Available immediately. Contact Dick Johnson, 1044 Westwood, Faribault, Minn. (507) 334-6735.

VIDEO PATCH PANELS. Trompeter, 48 Patches on each panel. New over \$400.00. Used \$200.00. New condition. 12 available. J.D. Ivey Corporation, 617 W. Central Blvd., Orlando, FL 32801. (305) 843-8982.

SPOTMASTER, FIDELIPAC, RUSSCO, ROH, ELECTRO-VOICE, OTARI, RAMKO, SCOTCH, STANSON, NORTONICS, SHURE, SENNHEISER, TELEX, MAGNECORD AND VIKING are all items distributed and serviced by COMMUNICATION MEDIAS/BROADCAST COMPONENT DISTRIBUTORS, P.O. Box 54, Allentown, PA. 18105. (215) 437-0607. "Sudden Service" our specialty.

EQUIPMENT FOR SALE (Cont'd)

Three Eimac 4W, 20,000A's, new in factory cartons, \$2,500.00 each. Lee Ellis, KGLO-TV, Mason City, Ia. (515) 423-1871.

BROADCAST AND RECORDING EQUIPMENT: Scully, V.I.F. International, Metrotech, Langevin, Electrodyne, Q.R.K., Micro-Trak, MRL, Nortronics, McMartin, U.R.E.I., E.V., A.K.G., Stevenson, Gately, D.B.X., Advent, Altec, Fairchild, Audio Designs, 3M, Magnecord, Telex, Inovonics, Nagra, Uher, Tape-Athon, Package Deals. Installations, Service, Request Flyer. Weigand Audio, Middleburg, PA. 17842. (717) 837-1444.

MICA AND VACUUM transmitting capacitors. Large stock; immediate delivery. Price lists on request. SURCOM ASSOCIATES, 1147 Venice Boulevard, Los Angeles, Calif. 90015. (213) 382-6985.

WHATEVER YOUR EQUIPMENT NEEDS—new or used—check us first. We specialize in broadcast equipment. Send \$1.00 for our complete listings. Broadcast Equipment and Supply Co., Box 3141, Bristol, TN 37620.

SPOTMASTER PARTS—24 hour service—repairs and rebuilding of your equipment. Franchised SPOTMASTER repair service. COMMUNICATION MEDIAS/BROADCAST COMPONENT DISTRIBUTORS, P.O. Box 54, Allentown, PA. 18105. (215) 437-0607.

For Sale. Television STL system Raytheon KTR 2 7 Ghz dual link for audio and video complete with antenna, trans. line and 8' x 12' reflector. Also TR 22 High Band color video tape machine. Write WXON-TV, Box 2020, Southfield, Mich. 48075 or call (313) 355-2901.

WANTED. Used IVC 870 and 825 recorders. Send price, age and condition to Recorders, P.O. Box 2751, Orlando, Florida 32802.

4-650 ft. towers \$6500.00 each. Many more. Ground wire 85¢ per xx. lb. Bill Angle, Box 55, Greenville, N.C. 27834. Tel. 919-752-3040.

EQUIPMENT WANTED

WANTED: Used RCA TTU-30 UHF Transmitter tunable to Ch. 50 preferred. R. Moffett, KOCE-TV, 15744 Golden West Street, Huntington Beach, Cal. 92647.

FRANCHISES AVAILABLE

NOTICE

IN VIEW OF THE EXPIRATION January 19, 1976, of its existing franchise with Bainbridge Video, Inc., the Village of Bainbridge is currently requesting proposals for a cable television franchise. Applications shall be prepared and submitted in accordance with the Request For Proposals, which may be obtained from the undersigned upon receipt of a non-refundable certified check in the amount of \$25.

Applications must be received by the Village Clerk not later than 12 o'clock, noon, January 26, 1976. Applications will be available for public inspection during normal business hours at the Town Hall in Bainbridge.

—H.E. McKown
Village Clerk
15 N. Main St.
Bainbridge, N.Y., 13733
967-3781

INSTRUCTIONS

First phone through tape recorded lessons at home plus one week personal instruction in Washington, D.C., Atlanta, Boston, Detroit, New Orleans, Minneapolis, Seattle, Denver, Portland, Los Angeles. Proven results. Our 17th year teaching FCC license courses. Bob Johnson Broadcast License Training, 1060D Duncan, Manhattan Beach, Calif. 90266. 213-379-4161.

PROGRAM SERVICES

"FREE" CATALOG... Everything for the Deejay! Custom I.D.s, Promos, Airchecks, Wildtracks, Books, FCC Tests, Comedy, and more! Write: Command, Box 26348-A, San Francisco 94126.

PROFESSIONAL CARDS

RALPH E. EVANS ASSOCIATES

Consulting TeleCommunications Engineers

AM-FM-TV-CATV-ITFS

3500 North Sherman Boulevard
MILWAUKEE, WISCONSIN 53216
Phone: (414) 442-4210

Member AFCCE

Midwest Engineering Associates

Consulting Engineers

F.W. Hannel, P.E.

BSEE; MSEE

6934A N. University, Peoria, Illinois

61614

(309) 692-4233

McCLANATHAN & ASSOCIATES

Consulting Engineers

APPLICATIONS & FIELD ENGINEERING
TURNKEY INSTALLATIONS — RADIO & TV
Domestic and Foreign

P. O. Box 750

PORTLAND, OREGON 97207

Phone: 503/246-8080

SALES OFFICES

Broadband Information Services, Inc.

29S Madison Ave.
New York, New York 10017

EASTERN & MIDWESTERN STATES

29S Madison Avenue
New York, New York 10017
212-685-5320
Kenneth F. Luker, Jr.

WESTERN STATES

1212 Hearst Building
San Francisco, California 94103
415-495-0990
William J. Healey & Associates

P.O. Box 49206
Los Angeles, California 90049
213-826-4543
Art Mandell

JAPAN

Nippon Keisoku Inc.
P.O. Box 410
Central Tokyo, Japan
Tokyo (03) 667-7681
Yoshi Yamamoto

ANNOUNCING:

THE MANUAL FOR THE THIRD REVOLUTION.

ENG/FIELD PRODUCTION HANDBOOK— GUIDE TO USING MINI VIDEO EQUIPMENT.

Electronic News Gathering is here today. It is being brought in by a flood of new mini-equipment—light-weight, high quality video cameras and videotape recorders.

It is the Third Revolution in TV, comparable to the quad videotape development of the 50's and the explosion into color of the 60's.

The ENG wave can only roll bigger and faster, but that is not all the new mini-equipment will do. It will generate a wave of instant, "anywhere" inexpensive documentaries, commercials, video for business and personal communications. Mini-equipment offers a new production technology: studios-without-walls, editing without engineers, professional results at amateur costs. This Electronic Field Production will be another video revolution.

This Manual is the first publication that describes the new mini-equipment in full detail, and provides a complete user's guide to both of the new technologies—ENG and Field Production.

This book is skillfully edited for the technical and non-technical reader alike; broadcasters and non-broadcasters. It's a great compilation of facts for the experienced hand, it's a primer for managers, directors, engineers and technicians looking at all electronic news and field production for the first time.

Ten big chapters: 1. the ENG/EFP revolution and where it's going 2. ENG systems in use 3. significance of all electronic systems 4. mini-portable cameras 5. portable videotape recorders 6. tape editors 7. time base correctors 8. microwave links 9. program audio and intercom 10. future developments.

**JOIN THE
REVOLUTION NOW
AND RECEIVE FIRST
COPIES OFF THE PRESS**



BMIE

BROADCAST MANAGEMENT ENGINEERING

295 Madison Ave. New York, N.Y. 10017

Please send () copies of ENG/Field Production Handbook at \$9.95 per copy.

Name _____

Address _____

City _____ State _____ Zip _____

Total Amount \$ _____

N.Y.S. Residents 7% Sales Tax _____

Total enclosed \$ _____

Foreign orders: add \$1 for postage & handling.

NEW LIT

center. The system is engineered as a fully integrated film/slide/live pickup unit. Capable of using as many as three film sources plus live camera pickup, the LDH-16 system can transfer Super 8mm, 16mm film and 35mm slides to standard TV format. Video Systems Division, Philips Audio Systems Corp. **255**

Information covering a range of **pulse delay lines** built by Matthey Electronics and distributed by Television Equipment Associates is available. The catalog gives details of pulse delay lines with delay times of from 5 ns to 500 ns. Data includes size, performance and applications. TEA **256**

A six-page booklet describes the Model TK-76 **portable color camera** for ENG applications. The brochure lists preliminary specifications and its features. RCA Broadcast Systems **257**

A 12-page booklet outlines the uses, advantages and format of the **SMPTE/EBU Edit Code**. Simple sketches and diagrams make the basics of the code easy to understand for newcomers of electronic indexing, synchronizing and video and audio tape editing. EECO **258**

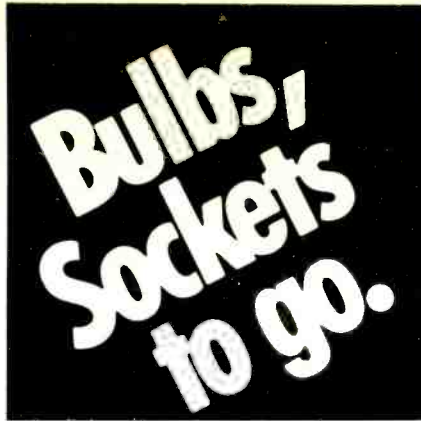

We're now national distributor of sensational new OSRAM HMI bulbs.

And still the country's biggest in-stock source of GE and Sylvania bulbs and sockets for studio, theater, tv and A/V. Now plus Leecraft sockets, too.

We specialize - we've got it all for you!

Send for 108-pg. stage/tv Lighting Handbook (\$50c mail and handling, please).

Nationwide service for over 25 years. Same-day shipment anywhere in US. Rush delivery in Manhattan.

**(212) JUDson 6-1620
BARBIZON ELECTRIC**

426 W. 55, NYC 10019

Circle 166 on Reader Service Card

ADVERTISERS INDEX

AKAI America Ltd.....	35
Amperex Electronic Corp.....	10, 11
Ampex Corp.	26, 27
Automated Processes	9
Barbizon Electric Co.	82
Belar Electronics Lab. Inc.	32
Blonder-Tongue Labs, Inc.	44
Broadcast Electronics, Inc.	38
Canon USA	57
Central Dynamics Ltd.....	17, 31, 69
Chyron Telesystems	16
Cinema Products Corp.	38, 75
Computer Image Corp.	61
Comtec	56
Consolidated Video Systems	71
Cooke Engineering	12
CSI	78
CMX Systems	15
DBX	22
Datatek Corp.	33
Datatron, Inc.	47
Ditch Witch Trenchers	8
Dynair Electronics Inc.	46
Dynasciences	72
Eastman Kodak Co.	29
Electro Impulse	40
English Electric Valve Co.	7
Fernseh, Div. Robert Bosch Corp. .	23
Fidelipac	30
Garner Electronics, Inc.	79
Grass Valley Group	5
Harris Corp.	51
IGM, Div. NTI	73
Ikegami Electronic Ind. Inc.	41
International Tapetronics Corp.	37
JVC Industries, Inc.	21
Jamieson Film Co.	65
LPB, Inc.	78
Lenco Inc.	14
McMartin Industries, Inc.	43, 73
Microtime, Inc.	Cover 3
National Video Corp.	39
Nurad, Inc.	18
Potomac Instruments	18
Rapid Q	82
RCA Broadcast Systems	13
RCA Service Company	36
Recortec, Inc.	68, 76
Shintron Co.	34
Sony Corp. of America	Cover 4
Spectra Sonics	72
Studio Tape Exchange	82
Systems Marketing Corp.	25
TeleMation Inc.	50, 54
Telemet	63
Telex	55
Television Equipment Assoc.	77
Television Research Intl.	Cover 2
Thompson CSF Labs	45
Tokyo Shibaura Electric Co. Ltd.	19
Tower Painting	79
UMC Electronics Co.	79
Ultra Audio Products	77
UREI	20
Videomax	3
Wilkinson	53

\$19⁹⁵ NEW 3/4" U 60 MINUTES ea. VIDEOCASSETTES

30 Min.	\$15.50
20 Min.	\$13.95
10 Min.	\$12.00

GUARANTEED RECONDITIONED AND NEW VIDEOTAPE

ALL FORMATS • LOWEST PRICES

Studio Tape Exchange Inc.

Nancy Gordon (212) 265-3740
366 West 46th Street
New York, NY 10036

Renée Ross (213) 466-8101
6424 Santa Monica Blvd.
Hollywood, Ca. 90038

Circle 169 on Reader Service Card

Take a "Q" from us!



Get the smallest cart machine available
Get automatic fast-forward standard
Get quiet, cool operation
Get the configuration to fit YOUR needs

RAPID-Q^{T.M.}

FROM **GARRON ELECTRONICS**

1216 KIFER ROAD, SUNNYVALE, CA 94086 (408) 736-8737

Circle 171 on Reader Service Card